

Modeling and Simulation of Reverse Power Relay for Generator Protection

Muhammad Mohsin Aman¹, *Member IEEE*, Ghauth Bin Jasmon¹, *Senior Member IEEE*, Qadeer Ahmed Khan², Ab. Halim Bin Abu Bakar¹, *Member IEEE*, Jasrul Jamian Jamian³

Abstract--Modeling tools are useful for basic understanding of power system, particularly for new engineers. Such tools help the new engineers to modulate the system under normal and faulty conditions. This paper presents the modeling and simulation of digital reverse power relay on MATLAB/Simulink®. Various data conversion steps in digitization of a signal are also discussed. In the past, electromechanical relays were commonly used, now such relays have been replaced with high accuracy and high speed digital relays. Fast operation of relay is desirable, particularly for such type of faults which could lead to system blackout. Digital relays offer other advantages also, in term of multiple variable settings and compact size. In this paper, the relay performance is tested on 11kV synchronous generator, connected with 220kV through a step up transformer.

Keywords – Reverse power relays, Relay Modeling, Digital relays.

I. INTRODUCTION

PROTECTION relays play a very important role in the safe and reliable operation of power system. Insecure or failed protection systems may make the situation worse and lead to the system blackouts. All faulted conditions do not lead to such situations. Faults that causes such situations include N-1 contingency of line, overloads, reverse power flow (loss of mechanical input) and others [1]. A typical protection scheme is an arrangement of various types of relays such as overcurrent, short circuit relay, over-under voltage, over-under frequency relays and others. In 90's, most of the relays in power system were electromechanical, later on replaced with solid-state. Now both types of relays are being replaced with digital relays. Digital relays offer advantage of fast in operation, small in size and reliable in operation in case of power system fault [2-3]. The relay also offers advantage in terms of their sensitivity and wide range controlling.

Simulation tools offer great help particularly for fresh engineers and researchers to familiarize with real operation of power system [4]. As a researcher, the behavior of the system could be seen under different scenarios and results could be manipulated, which is not possible in healthy system. MATLAB also offers simulation based Power System

Analysis Toolbox for power system engineers. However this toolbox does not have protection relays modules. In this paper, the design of a digital Reverse Power Relay (RPR) is constructed on MATLAB/Simulink®. Several digitization process also include in signal processing. Such steps are also discussed in this paper.

II. REVERSE POWER RELAY (ANSI CODE - 32)

Reverse Power Relays (RPR) are commonly used in power system for detecting motoring action of synchronous generator. This condition normally occurs when the prime mover (engine or turbine) fails, however the field winding is still connected with the excitation system. This resulted in motoring action and the machine behaves like a synchronous motor connected with large power system. In such condition, the turbines become the active load on that machine. Motoring action draws power from the system to drive the prime mover and can cause severe damage to the prime mover. This condition is not desirable and there is an objectionable temperature rise in case of steam turbine. Therefore such conditions need to detect quickly and the GCB should be tripped [5]. Diesel engines and gas turbines are less susceptible to immediate damage, but unburned fuel may present a fire or explosion hazard.

TABLE I
MOTRING REVERSE POWER REQUIREMENTS AND
REVERSE POWER POSSIBLE DAMAGES [6]

Prime Mover	Motoring Power (% of rated)	Possible Damage	Protection Setting
Diesel Engine	5-25	Fire/Explosion due to un-burnt fuel	50 % of motoring
		Mechanical Damage to gearbox/shafts	
Gas Turbine	10-15 (Split Shaft)	Gear box damage	
	>50% (Single Shaft)		
Hydro	0.2-2 (blades of water)	Blade and runner cavitations	
	>2 (blades of water)		
Steam Turbine	0.5-6	Turbine blade damage	
		Explosion due to rise of temperature of steam	
		Gearbox damage on geared sets	

¹ Muhammad Mohsin Aman, Ghauth Bin Jasmon and Ab. Halim Bin Abu Bakar are working with University of Malaya, Malaysia. They can be reached at mohsinaman@gmail.com, ghauth@um.edu.my, halim5389@gmail.com respectively.

² Muhammad Qadeer Ahmed Khan is working with ENI Corporate University, Italy. He can be reached at qadeer88@gmail.com.

³ Jasrul Jamian Jamian is working with Universiti Teknologi Malaysia. He can be reached at jasrul@fke.utm.my.

Table 1 gives the details of the potential problems for various prime mover types and the typical settings for reverse power protection [6]. The RPR is usually set to 20% to 50% of the motoring power required by prime mover. Here the word ‘motoring power’ means the minimum amount of power required by the generator to run the prime mover at the rated rpm. This data is usually obtained from the manufacturer of the prime mover [6].

For illustration of motoring power and reverse power relay setting, an example is given below.

Consider a 440MVA generator, with no load losses of generator 1.785 MVA and permissible motoring time is 15sec. the other necessary data include:

- No Load Loss of Turbine 1,350 KW
- No Load Loss of TG unit 3,135 KW
- Permissible Motoring Time 60 Sec.
- Relay Constant 1 pu. = Generator KVA
- The permissible motoring setting is 30%.

For RPR settings, two parameters need to be calculated include (1) Reverse power trip level (2) Time delay.

For Safe Operation -- Reverse Power Trip Level:

- Trip Level < No load loss of TG unit * 0.3
= 3,135 * 0.3 = 940.5 KW
- Pick up = Trip level / relay constant
= 941 / 440 = 0.0021 pu
- Setting = - 0.0021 pu (924kW)

Reverse Power Trip Delay

Trip Delay < Permissible Motoring time
Setting = 750 Cycles for 50Hz system (15 Sec)

Reverse power condition could also occur during synchronization, when the frequency of the machine to be synchronized is slightly lesser than the bus bar frequency and the breaker is closed. In such condition power will flow from the bus bar to that machine. Therefore during synchronization frequency of the incoming machine is kept slight higher than that of the bus bar. This ensures that the machine takes on load as soon as the breaker is closed [7].

RPR could also be used for islanding detection. Whenever the difference between load and available generation is not sufficient to obtain an appreciable rate of change of frequency but the active power continues to flow into the grid to feed external loads, RPR with UF can be used to detect loss of grid supply[8]. The other applications of reverse power relay could be seen in [9].

III. PRINCIPLE OF REVERSE POWER RELAY

A reverse power relay is a directional relay that is used to monitor the power flow from generator (running in parallel with another generator or the utility) and in case of abnormal condition take appropriate action. Under abnormal condition, the direction of power changes from the bus bar into the generator. This condition normally occurs when prime mover fails. The real power drawn from the grid is quite small compared with the generator rating. However stator current

undergoes 180° phase shift normally referred as Maximum Torque Angle (MTA) as shown in Fig. 1. This suggests that if we use a directional relay with MTA of 180° (using generator phase angle conventions) then it could detect the loss of prime mover as the current phasor would reverse and enter the trip region. However the magnitude of this reversed current phasor is quite small compared to the forward current as the generator draws just enough real power to meet the losses and drive the turbine. Hence, the directional relay for detecting the loss of prime mover needs to have a high degree of sensitivity compared to directional relays used for over-current application [10].

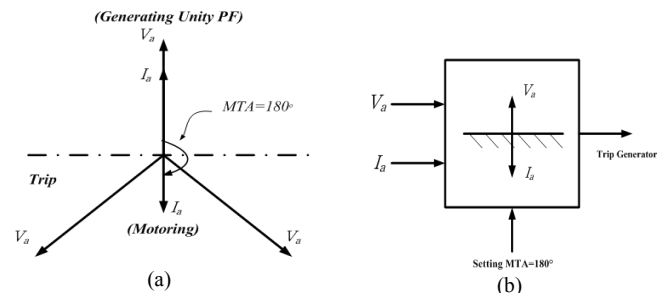

Figure 1. (a) Phasor Representation (b) Block Representation of Current and Voltages under Reverse Power Flow

The installation of RPR on a power system is shown in Fig. 2. For applications where a protection sensitivity of better than 3% is required, a metering class CT should be employed to avoid incorrect protection behavior due to CT phase angle errors when the generator supplies a significant level of reactive power at close to zero power-factor. The reverse power protection should be provided with a definite time delay on operation to prevent spurious operation with transient power swings that may arise following synchronization or in the event of a power transmission system disturbance [6].

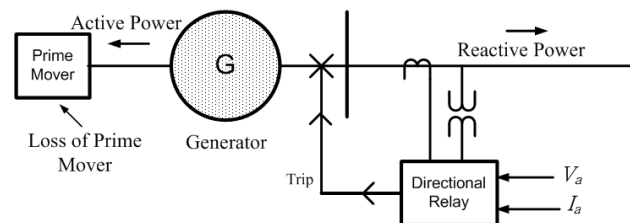

Figure 2. Reverse Power Relay in Power System

Let ‘ δ ’ is the angle between current and voltage on phase A, then under normal direction of load flow $-90^\circ < \delta < 90^\circ$ and in case of reversed power flow $+90^\circ < \delta < 270^\circ$ [11]. It has been observed that the overlapping interval between voltage and current is longer than their non-overlapping interval during normal conditions as shown in Fig. 3a. However this overlapping reduces to a low level in case of reverse power flow, shown in Fig. 3b.

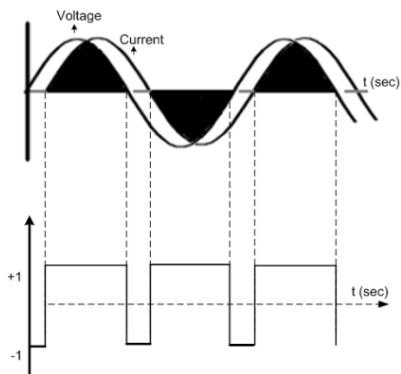

Figure 3a. Angle between Voltage and Current Waveforms under Normal Conditions

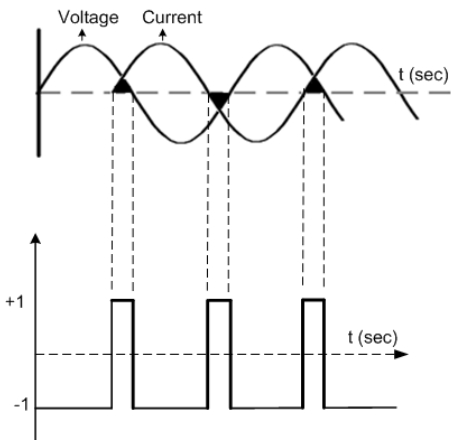

Figure 3b. Angle between Voltage and Current Waveforms under Fault Conditions

This difference of overlapping interval under normal and reversed power flow conditions will be used to implement the directional element of the relay.

IV. MODELING OF REVERSE POWER RELAY

To model the reverse power relay, the RPR is divided into three parts directional element, delay element and hold block as shown in Fig. 4.

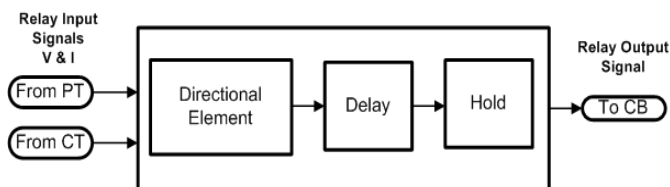

Figure 4 Block Diagram For Implementing Reverse Power Relay

A. Directional Element

In the directional element, low voltage and current signals from CT and PT signals are converted to a perfect square wave form with ± 1 values. The two level signals are then

multiplied to give an output '1' during the overlapping and '-1' for the non-overlapping interval. The product is then integrated from 0 to '-L'. The upper limit of the integrator is set at '0' value so that under normal load flow conditions the integral always remains less than 0. However, under reversed power flow conditions the integral output tends to fall until it reaches the threshold value 'L'. In present case L is set at 0.01, however any value could be selected depending on the amount of reverse power. The block diagram for implementing the directional element is shown in Fig. 5 and its implementation on Simulink® is shown in Fig. 6.

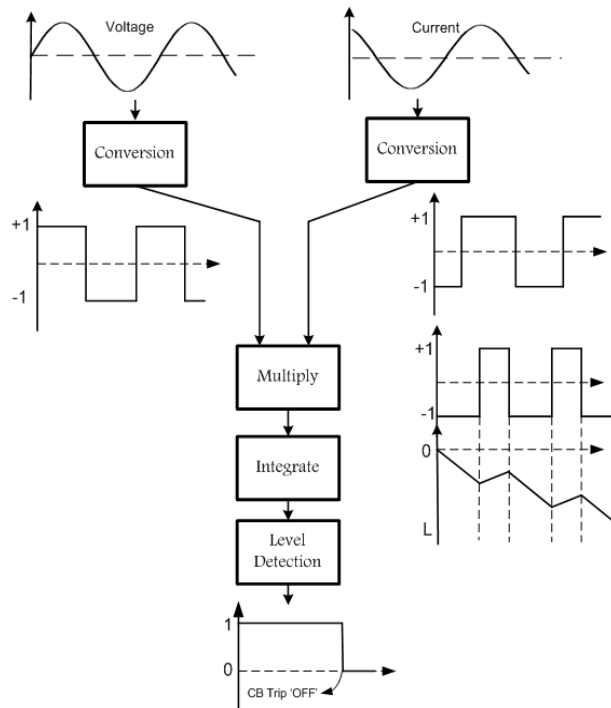

Figure 5. Concept Diagram for Implementing Directional Element.

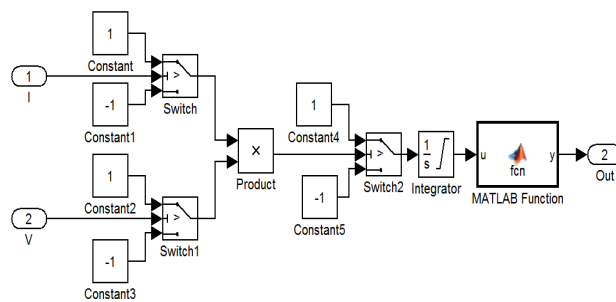

Figure 6. Modelling of Directional Element on SIMULINK®

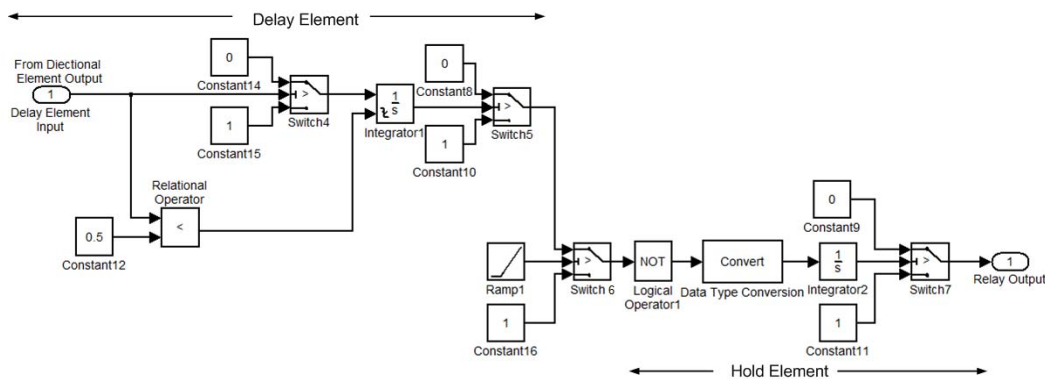

Figure 7. Modeling of Delay Element and Hold Element on SIMULINK®

B. Delay Element

The purpose of the delay element is to prevent the relay from sending a false trip signal to the CB during transient or a temporary fault conditions. The logic for implementing delay element is represented Fig. 7 (left side).

The output of the directional element (input of delay element) is sent to a decision block (switch4) whose output is '0' in case of normal and '1' in case of abnormal (reverse power) conditions. This output in turn is integrated. The value of the integral is compared with the threshold level 'T', whose value is set equal to the amount of delay time desired. When the value of the integral is less than the level T, the output of the delay element will be 1, indicating normal condition.

Under stable condition, since the input received at the integrator is '0'. Hence the value of the integrator will always be '0' (less than value 'T'), therefore the output of the delay element will correspondingly be 1. However under permanent abnormal condition, the input to the integrator will be '1' and after 'T' seconds, the integral value will exceed T, causing the delay element to produce

'0' output to indicate fault condition.

In case a temporary fault or transient condition occurs for less than 'T' seconds, the integrator will be reset to '0' by the relational operator, once the fault disappears.

C. Hold Block

The purpose of the hold block is to keep the state of the relay stable after the relay has tripped. This is because once the CB has opened, the fault will cease to exist, indicating a normal condition and tempting the relay to again send a '1' signal to the CB, causing it to again close.

The logic for implementing the hold block is shown in Fig. 7 (right side). The '0' value from the delay block is first inverted and then integrated. As soon as the value of the integral exceeds '0' value, the o/p of the hold block will change from '1' to '0'. However here integrator cannot reset therefore once the integral exceeds its threshold of '0' it will never come back to that value and hence the output of the hold block will always be '0' value.

The switch block, between delay and hold element is used only to prevent the relay from false tripping during starting transients period.

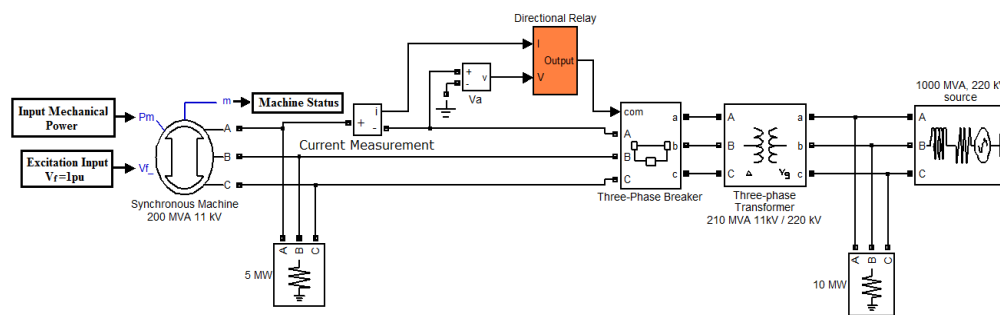

Figure 8. Reverse power relay model in power system

V. SIMULATIONS AND RESULTS

For testing and simulation of designed relay, a 200MVA 11kV synchronous machine is used, connected with 220kV network through a step up transformer 11/220kV as shown in Fig. 8. The details of the system are given in appendix.

The relay is tested under different scenarios. The test conditions, results and discussions are given below.

A. Case 1:

This is a normal case in which the mechanical input to the generator changes from 0.2pu to 0.8pu at 20 sec. The input/output power and relay status observed is shown in Fig. 9. In this case, relay does not trip, however output power oscillate initially about the equilibrium point.

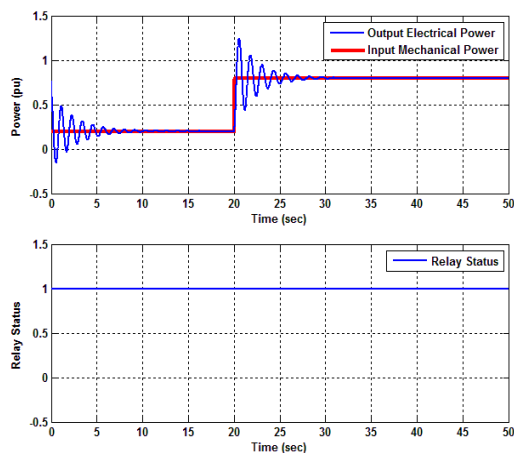

Figure 9. Relay performance (a) Input/Output Power (b) Relay Status

B. Case 2:

In second case, the mechanical input to the generator changes from 0.5pu to 0.1pu at 90 sec. The input/output power and relay status observed, shown in Fig. 10.

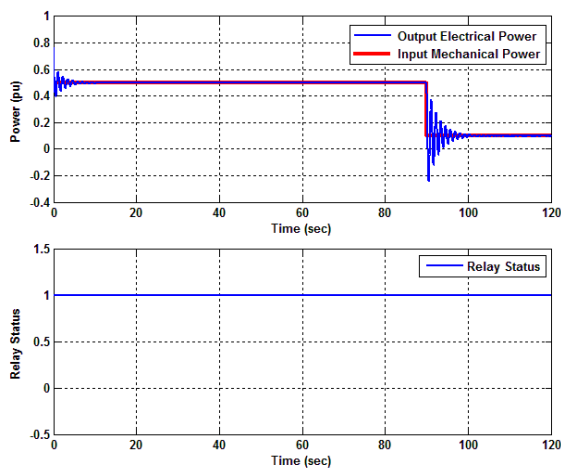

Figure 10. Relay performance (a) Input/Output Power (b) Relay Status

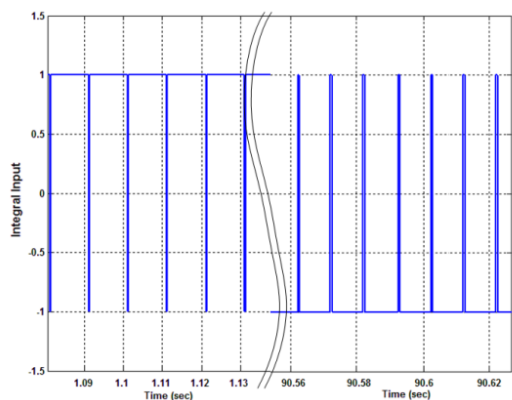

Figure 11. Integrator Input (From Switch2 in directional element)

In this case relay does not trip. However at 90 sec, the electrical power reverses (-0.2pu) momentarily. This is also a case of stable system. The integral input of directional element is plotted in Fig. 11. Here it could be observed that the integral input changes direction (-ve) momentarily but later on stable (+ve).

C. Case 3:

In third case, the mechanical input to the generator changes from 0.5pu to -0.1pu at 90 sec. The input/output power and relay status observed is shown in Fig. 12.

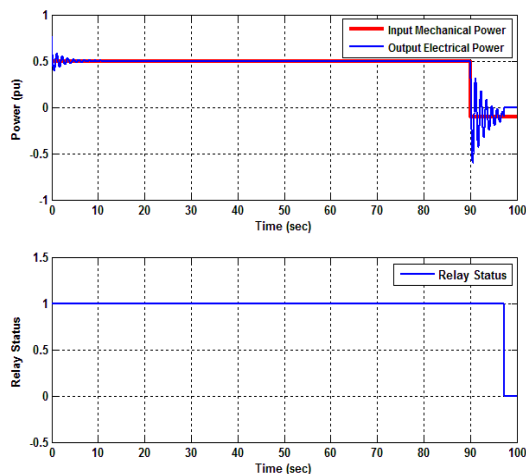

Figure 12. Relay performance (a) Input/Output Power (b) Relay Status

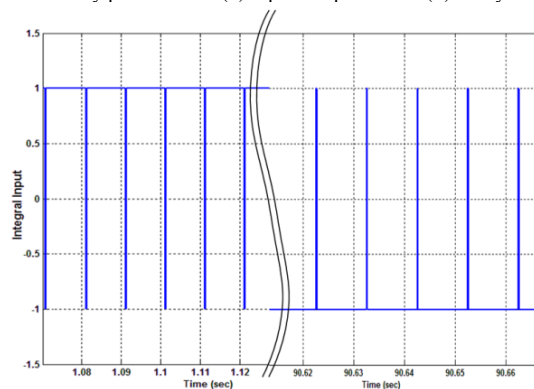

Figure 13. Integrator Input (From Switch2 in Directional Element)

Here it could be observed that the relay trip around 7 sec after the fault has occurred on 90 sec. The integral input of directional element is also plotted, shown in Fig. 13. It could be observed that overlapping pattern is in agreement with Fig. 3b, thus the relay tripped.

D. Case 4:

Case 4 is a cumulative case to show the performance of the reverse power relay under different conditions. The mechanical input changes to the generator changes several times from 0 to 140 sec.

From Fig. 14, it could be observed that the system operates safely during all mechanical transients and safely isolated the generator at 107sec, when mechanical input loss occurred.

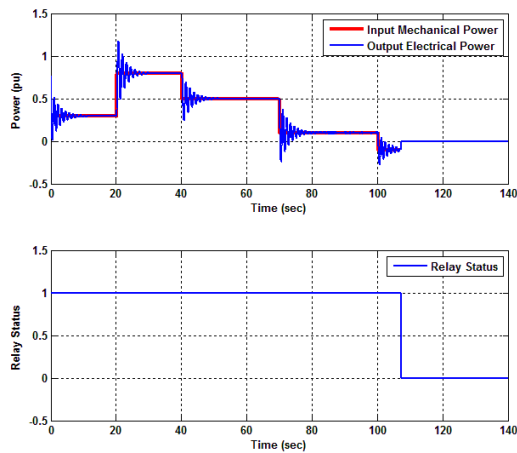

Figure 14. Relay performance (a) Input/Output Power (b) Relay Status

The delay time integral output (Integrall in Fig. 7) is plotted in Fig. 15(a).

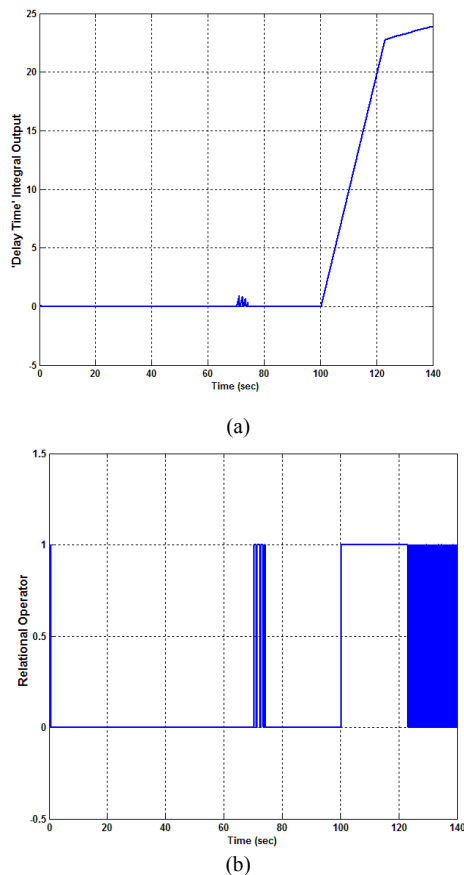

Figure 15. (a) Delay Time Integral Output (b) Relational Element Output

Fig. 15b shows during transients at 70 seconds, the integral output rose momentarily, which is reset by the relational operator. This result reliable operation of the relay at all time.

VI. CONCLUSION

The paper has presented the modeling and simulation of digital reverse power relays using MATLAB/SIMULINK®. The proposed relay model has been demonstrated by

considering different examples as case studies. The digitization process is also discussed in details. As compared to other power relay model in existing power system softwares, MATLAB offers advantage in terms of their flexibility. Researchers could modify the testing parameters as well as the design of the relay.

These models have been contributed to MATLAB online resources to support their Power System Tools. The complete model with case studies could be accessed on [12]. These models help the fresh engineers to develop the analytical skills and visualize the system behavior under normal and transient conditions.

VII. APPENDIX

Generator:

$$V_{L-L}=11\text{kV} \quad f=50\text{Hz} \quad S=200\text{MVA}$$

Transformer:

$$V_P/V_S(L-L)=11\text{kV}/220\text{kV} \quad f=50\text{Hz} \quad S=210\text{MVA}$$

Utility Source:

$$V_{L-L}=220\text{kV} \quad f=50\text{Hz} \quad S=1000\text{MVA}$$

VIII. ACKNOWLEDGMENT

The first author gratefully acknowledges the financial support given by the University of Malaya, under Bright Spark Programme (BSP) for the PhD work in this area.

IX. REFERENCES

- [1] S. Tamronglak, et al., "Anatomy of power system blackouts: preventive relaying strategies," *Power Delivery, IEEE Transactions on*, vol. 11, pp. 708-715, 1996.
- [2] Vahidi, B. and Esmaeeli, E., "MATLAB-SIMULINK-based simulation for digital differential relay protection of power transformer for educational purpose". *Computer Applications in Engineering Education*.
- [3] Yalla V.V.S. Murty, a and W.J. Smolinskib, "Design and implementation of a versatile digital directional overcurrent relay" *Electric Power Systems Research* Volume 18, Issue 1, January 1990, Pages 47-55 Published by Elsevier B.V."
- [4] ABB, "SRW Reverse Power Relay" Available on: [http://www05.abb.com/global/scot/scot229.nsf/veritydisplay/5a5acc6d19070dd985256ead0068d04c/\\$file/41-252A.pdf](http://www05.abb.com/global/scot/scot229.nsf/veritydisplay/5a5acc6d19070dd985256ead0068d04c/$file/41-252A.pdf) [Accessed on: 03 Mac 2012].
- [5] M. M. Aman, et al., "Digital Directional and Non-Directional Over Current Relays: Modelling and Performance Analysis," *NED University Journal of Research*, vol. 8, 2011.
- [6] Peter Rush *Network Protection & Automation Guide* ALSTOM T&D Energy Automation & Information (2002) ASIN: B00480IKQO.
- [7] Online Article Available on: <http://www.electrotechnik.net/2009/06/reverse-power-relay-function-and.html> [Accessed on 25 Feb 2012]
- [8] K. Rajamani and U. K. Hambarde, "Islanding and load shedding schemes for captive power plants," *Power Delivery, IEEE Transactions on*, vol. 14, pp. 805-809, 1999.
- [9] Basler Electric Available from: <http://www.electricalmanuals.net/files/RELAYS/BASLER/BE1-32R/9171100990R.pdf> Accessed on: 03 March 2012," September 2007.
- [10] Pathinkar, Y.G. and Bhide, S.R., "Fundamentals of Power System Protection", PHI Learning Pvt. Limited (2008)
- [11] Arun G. Phadke, James S. Thorp "Computer relaying for power systems" John Wiley & Sons, Inc. New York, NY, USA ©1988 ISBN: 0-471-92063-0."
- [12] MATLAB File Exchange. Author: Muhammad Mohsin Aman <http://www.mathworks.com/matlabcentral/fileexchange/authors/126622>.