

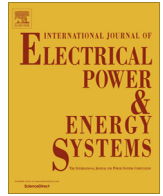

Contents lists available at ScienceDirect

Electrical Power and Energy Systems

journal homepage: www.elsevier.com/locate/ijepes

A hybrid PSS–SSSC GA-stabilization scheme for damping power system small signal oscillations



Mohammad Ghanbari Jolfaei^a, Adel M. Sharaf^{b,*}, Seyed Mohammad Shariatmadar^c,
Mohammad Bayati Poudeh^d

^a Young Researchers and Elite Club, Central Naragh Branch, Islamic Azad University, Naragh, Iran

^b Sharaf Energy Systems, Inc, Fredericton, NB, Canada

^c Department of Electrical Engineering, Naragh Branch, Islamic Azad University, Naragh, Iran

^d Department of Electrical Engineering, Naein Branch, Islamic Azad University, Naein, Iran

ARTICLE INFO

Article history:

Received 17 June 2015

Accepted 28 August 2015

Keywords:

Power system stability

SSSC

PSS

Dynamic stability enhancement

Genetic algorithm

ABSTRACT

Nonlinear and fast quasi dynamic type loads of different time-varying ranges are introduced to the electric grid systems due to renewable Energy, distributed Generation and Power electronic AC–DC–AC interface converters used in several parts of the power network, the dynamic small signal electromechanical modes are destabilized and dynamic stability limits of AC system is reduced. FACTS – Flexible AC Transmission Devices with conventional coordinated power system Stabilizers are utilized to improve dynamic stability margins and damp unstable and oscillatory electromechanical modes of oscillations. Coordinated Flexible Soft Computing Control Strategies are proposed for damping modes of through supplementary damping torques provided by Static Synchronous Series Compensator – SSSC in addition to classical Power System stabilizers – PSS.

To coordinate the dual action of both SSSC and PSS devices a Genetic algorithm Tuning Controller is applied. The dynamic simulation results for optimized controllers are validated using Matlab/Simulink Software Environment.

© 2015 Elsevier Ltd. All rights reserved.

Introduction

The growing demand for energy and rising cost of fossil fuel combined with environmental Green House Gas (GHG) Emissions and Global warming have renewed the interest for interconnected large energy pools connecting neighboring electric grids together and transmit bulk energy during peak times of load demand; while, the linking of the power systems together introduces some modes of electromechanical oscillations and frequency deviations within the range of 0.2–2 Hz in the power system. When such electromechanical oscillations persist in the electric system, the full use of the power system is limited and there is the possibility of the generation-load mismatching and dynamic instability. On the other hand, these oscillations will have a negative effect on the turbine shaft fatigue of turbine-generator and gradually bring about great damage and possible torsional oscillations and sub-synchronous resonance conditions in case of in the long-compensated transmission lines with series capacitor banks.

Electromechanical damping systems as well as power system stabilizers are employed in traditional methods; although they reduce oscillations in the power system, they ultimately bring about other negative effects such as increasing the short circuit currents or making the system more complicated [1,2].

One of long proven and effective methods for damping electromechanical oscillations is the use of the power system stabilizer (PSS) which has highly been taken into consideration due to its suitable effect on the damping local modes of oscillations [3]. Classical control methods like PID, lead-lag compensation stages, placement of the poles. New control methods such as fuzzy logic control, adaptive/comparative control, neural network based and predictive control are employed in the control section of this stabilizer which are significant for their performance [4–6].

New development in power electronic devices and emerging VSC–FACTS based converter topologies offer fast controllability and enhanced dynamic performance and better FACTS performance [7]. Applications of the FACTS cover voltage control, loss reduction, voltage stabilization, peak load release, energy efficient operation and improvement of transient and dynamic stability, and Fault-Ride through as well as Flicker control.

* Corresponding author. Tel.: +1 506 453 4561.

E-mail address: profdrsharaf@yahoo.ca (A.M. Sharaf).

One of the FACTS devices implemented is static series compensators (SSSC) and because of its dynamic fast performance in voltage and current controlling, it is useful in decreasing and also damping the oscillations in power system [8–13]. Thyristor-Controlled Series Capacitor (TCSC) is a simple FACTS device with series link which improve the stability of the power system and limit the low frequency oscillations (less than 2 Hz) by controlling the effective reactance of the transfer line [9–14,33]. The static VAR compensator of the reactive power (SVC) as a parallel compensator can play the role of a controllable variable reactor to absorb or generate the reactive power to stabilize the circuit voltage within the range of inductive to capacitive [10].

SSSC as series FACTS device has a DC capacitor in structure of voltage inverter and delivers a balanced synthesized three-phase voltage to the network (VSC) [10,11]. Although about this voltage in order to have only reactive power exchange with the network, it should be perpendicular to the current line. In fact, if this voltage has a phase priority relative to the current by $\pi/2$ Radian, the VSC acts like an inductive and if it has a phase lag, it acts such a capacitor.

Considering the above advantages, SSSC can be an elegant low cost solution for active and reactive power control in long transmission lines and enhance the transfer power capability of the line; ultimately, effectuating the stability of the power system. By placing SSSC in the power system, there is the possibility of increasing the reliability of the power network and preventing inappropriate exploitation of the generators and cases leading to the loss of a part of the network loads [16,17]. In the direction of improving the SSSC performance and damping the power oscillations, different studies have been performed on the regulation of its control parameters and the effect of the control mode and its degree of compensation on the dynamic and transient stability in different tasks [15–19]. In regulating the SSSC control parameters under different load conditions, it should be acted in a manner that the damping and undamping modes are directly transferred to the stable intended region without damaging the system mode conditions [20–28]. A hybrid compensator was used in a study [29], in a manner that two phases were series connected by the capacitor and the third phase was series connected by SSSC and compensated by the fixed capacitor to damp the interregional oscillations in multi-machine model. In regulating the controlling parameters of the SSSC set, intelligent searching methods are used to damp the oscillations of the power [16].

Common control tuning methods such as the relocation of poles [17], compensation of phases [18], compensation of the residuals [22], and modern control methods have been used for the design and control of the power system stabilizers in the researches performed so far [21]. The disadvantages of most tuning methods for controllers are their complexity and computational burden with high volume of computations, low convergence velocity, and also the possibility of obtaining local and optimal answers. Today, intelligent methods such as the method of the group of particles [23,24], genetic algorithm [25], differential algorithm [26], and fuzzy logic [3,27] are extensively used in the design of the power system stabilizations to reduce the problems existing in the common design methods.

In this paper, the SSSC compensator system and the power system stabilizer are regulated and coordinated by the genetic algorithm to increase the stability of the power network confronting load changes and to reduce oscillations resulting in results. The result of its performance is simulated in Matlab–Simulink. In the next section of this paper, the structure and performance of SSSC along with proposed controller are studied. The third part of this paper is devoted to the modeling of a power system along with power stabilization and SSSC. Then, in the simulation section, the

effectiveness of the optimal control of the power stabilizer and SSSC in different conditions are illustrated.

The SSSC-structure and controller

The Static Synchronous Series Compensator (SSSC) is a voltage source convertor of the solid state with the capability of generating a controllable AC voltage connected to the transmission line in series as depicted in Fig. 1. By injecting the V_q voltage in series with the transmission line, SSSC enjoys the capability of compensating the transmission line impedance. V_q is perpendicular to the line current and is able to change the line impedance from inductive property to capacitive property. Also, the value of the injection V_q is independent of the line current size influencing the distribution of the transmission line power [14]. The V_q changes are done by the voltage source convertor connected to the secondary of the coupling transformer. The rate of compensation can be continuously changed by a change in the size and the injection voltage phase; this element can be exploited both in the inductive and capacitive states. VSC as one of the devices of the power electronic generates an AC voltage from a DC voltage source performed by a capacitor connected to the DC section of the convertor. To compensate the transformer and convertor losses and the capacitor charge holding, a small value of the real power is drawn from the transmission line in consumption form.

The single-machine system connected to infinite bus in the presence of SSSC is shown in Fig. 1. The transformer reactance, the transformer reactance connected to SSSC, and the transmission line reactance are represented by X_{ts} , X_{sct} , and X_{line} , respectively. Also, V_t and V_b are the generator terminal voltage and the infinite bus voltage, respectively. In a general state, SSSC includes a three-phase voltage source convertor connected in series to the transmission line through a transformer. The performance of SSSC is based on the PWM technique and V_{INV} , C_{DC} , m , and ψ are the series injected voltage, DC link capacitor capacitance, modulation index size, and the voltage phase angle, respectively.

Sample power system model with SSSC

In order to analysis the power system oscillations it is better to model the system in small signal states. In this modeling the single machine infinite bus network in Fig. 1 is modeled by Heffron–Phillips model which is shown in Fig. 2 [1–32].

By the linearization of the nonlinear dynamic model of state space of system in nominal operating point, the following small signal linear dynamic model of the following small signal is obtained as (1), and the details of equations are mentioned in [28].

$$\begin{aligned} \Delta \dot{\delta} &= \omega_0 \Delta \omega \\ \Delta \dot{\omega} &= \frac{\Delta P_m - \Delta P_e - \Delta P_D}{M} \\ \Delta \dot{E}'_q &= \frac{-\Delta E_q + \Delta E_{fd}}{T'_{d0}} \\ \Delta \dot{E}_{fd} &= \frac{-\Delta E_{fd} + K_A(\Delta V_{ref} - \Delta V_t)}{T_A} \\ \Delta \dot{V}_{DC} &= (K_7 \Delta \delta + K_8 \Delta E'_q + K_9 \Delta V_{DCm} K_{pm} \Delta m) \\ \Delta P_e &= (K_1 \Delta \delta + K_2 \Delta E'_q + K_{pdc} \Delta V_{DC} + K_{pm} \Delta m) \\ \Delta P_q &= (K_4 \Delta \delta + K_3 \Delta E'_q + K_{qdc} \Delta V_{DC} + K_{pm} \Delta m) \\ \Delta V_t &= (K_5 \Delta \delta + K_6 \Delta E'_q + K_{vdc} \Delta V_{DC} + K_{pm} \Delta m) \end{aligned} \quad (1)$$

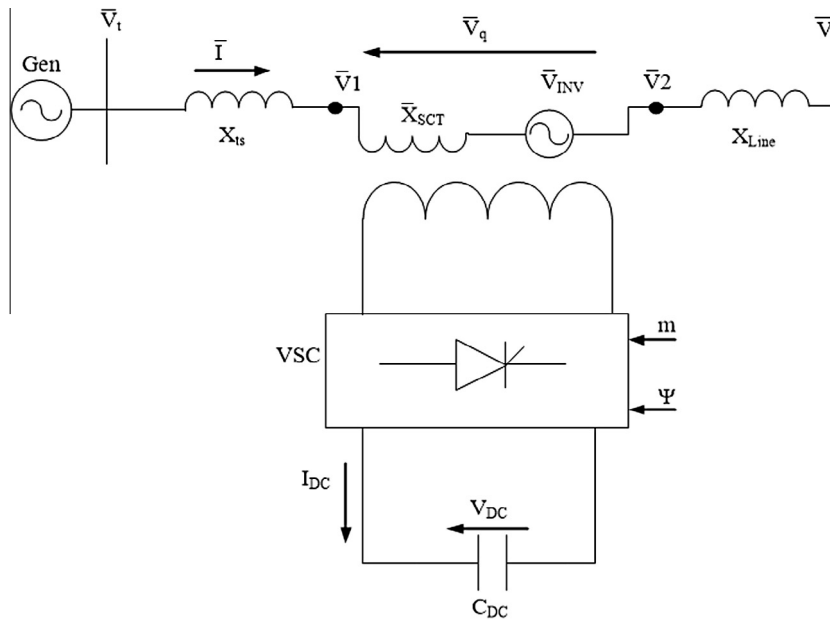

Fig. 1. Single-line diagram of single-machine power system connected to the infinite bus along with the SSSC series in transmission line.

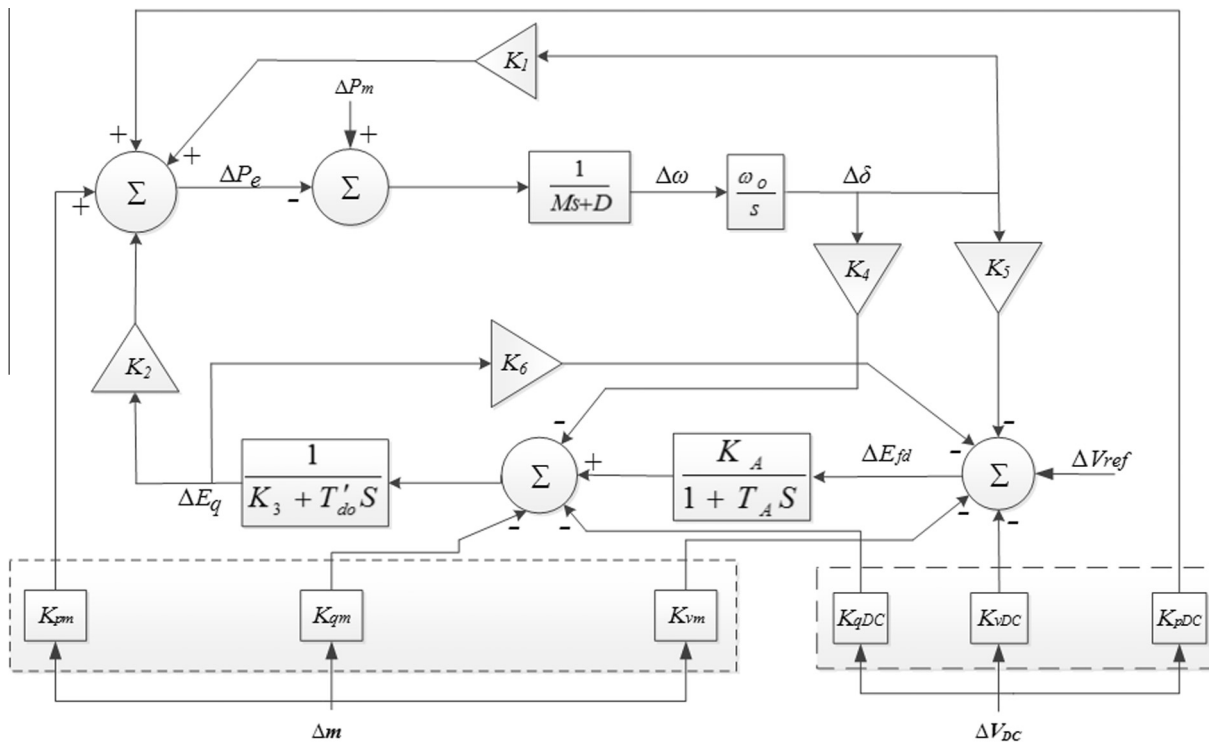

Fig. 2. Heffron–Phillips model for single-machine power system connected to infinite bus along with SSSC series in the transmission line [1].

With regard to Eqs. (1) and (2), the relations are ordered in the form of state equations. In Eq. (2), the state matrix of A and input gain matrix B are obtained as follows [32].

$$\dot{X} = AX + BU$$

$$X = [\Delta\delta \quad \Delta\omega \quad \Delta E'_q \quad \Delta E_{fd} \quad \Delta V_{DC}]$$

$$U = [\Delta m]$$

$$A = \begin{bmatrix} 0 & \omega_0 & 0 & 0 & 0 \\ -\frac{K_1}{M} & -\frac{D}{M} & -\frac{K_2}{M} & 0 & -\frac{K_{pdc}}{M} \\ -\frac{K_4}{T'_{do}} & 0 & -\frac{K_3}{T'_{do}} & \frac{1}{T'_{do}} & -\frac{K_{pdc}}{T'_{do}} \\ -\frac{K_A K_5}{T_A} & 0 & -\frac{K_4 K_6}{T_A} & -\frac{1}{T_A} & -\frac{K_A K_{pdc}}{T_A} \\ K_7 & 0 & K_8 & 0 & K_9 \end{bmatrix}^T \quad (2)$$

$$B = [0 \quad -K_{pm} \quad -K_{qm} \quad -K_{vm} \quad -K_{DCm}]^T$$

PSS-small signal model

Due to the effective damping performance of PSS in the power systems and their rather lower cost compared to other methods and control systems of power oscillations, they function as the assisting member alongside generators in a majority of the networks. The structure of PSS consists of a portion, a high-frequency filter, and phase compensation unit along with a filter unit which is studied in [1].

The high-pass filter is used to avoid uniform changes resulting from the input signal which is the terminal voltage changer. From the view of the interregional mode oscillations, the time constant of high-frequency filter is usually adjusted to 3 s to reduce phase leading within the frequency range of interregional modes and for the quantification of the reaction opposite to interregional modes. To prepare damping in oscillations, a PSS with phase leading properties should be taken into consideration to compensate the post-phase between the generator exciter input and electric output torque.

Complementary damping controller for the SSSC

The strategic use of the SSSC controller for the combined regulation of the active power, hence the improvement of the transient stability of the power system is shown in Fig. 3. For this purpose, the SSSC controller prepares the suitable voltage sanction for SSSC by the use of the power system parameters.

The signal entering the intended PI controller results from the deviation of the rotor speed and rotor angle and this set generates the Δm signal in a more effective manner for the SSSC controlling section. By precise regulation of the PI controlling parameters, the oscillations resulting from changes in the network can be damped effectively.

Control strategy

In order to study and compare the performance of the proposed hybrid control system with other controlling methods, the SMIB-Single Machine Heffron–Phillips model is used in this paper in which the block structure of SSSC and PSS are included in a model similar to that in Fig. 2 [30]. In this simulation, the system is studied in states without the presence of PSS and only with the help of optimal control SSSC; in the presence of the traditional PSS and optimal control SSSC; and also in the presence of optimal PSS and optimal control SSSC to clearly show the effect of the presence of each one.

The power system is required to change the input power rate of its generation section by changing the consumption power rate.

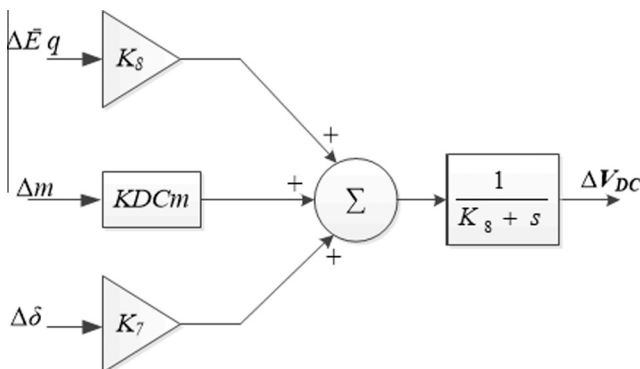

Fig. 3. SSSC complementary control system.

Therefore, the input power should be changed in the form of steam, water, or any energy supply force. With such changes, the system parameters suffer oscillations such as stresses appearing on the axis of the generator turbine. Although these stresses appear to be small, they gradually and collectively lead to the axis fatigue causing irreparable damages and even the breakage of the axis over a long period of time. Three states are considered in the analysis of the system performance; the load change error of the power network by 10% for a period of 3 cycles; permanent 10% load change error; and also a 10% load change error in the form of an increase and then a decrease.

In this section the genetic algorithm and the manner of its performance for finding the parameters of the control system are explained.

GA-genetic algorithm

The use of natural evolution for the optimization of the GA-based Genetic Algorithm-control systems has been of interest to the researchers long since. The parameters of the control system are considered as the genes of one chromosome in this method and then by forming a random population of different chromosomes; calculating the objective function related to each of the chromosomes; and employing the generation enhancement methods, the best answer that satisfies the minimum objective function is obtained. Fig. 4 illustrates the flowchart of the genetic algorithm stages [31].

Genetic algorithm GA is employed to properly regulate the controlling parameters proposed for SSSC and also the parameters of PSS. There are two PI controllers in the SSSC proposed controlling section in which the proportional and integral gains of each controller is considered as a set of the genes of the chromosomes of each genetic algorithm generation.

The PI controller coefficients are as follows:

$$G_{PI}(S) = K_p + \frac{K_i}{S} = \frac{K_p \cdot S + K_i}{S} \tag{3}$$

Furthermore, the PSS gain parameter and also the time constants of T_1 and T_2 of the power stabilizer in this paper are regulated by genetic algorithm and considered as other variables optimally effective in the improvement of stability.

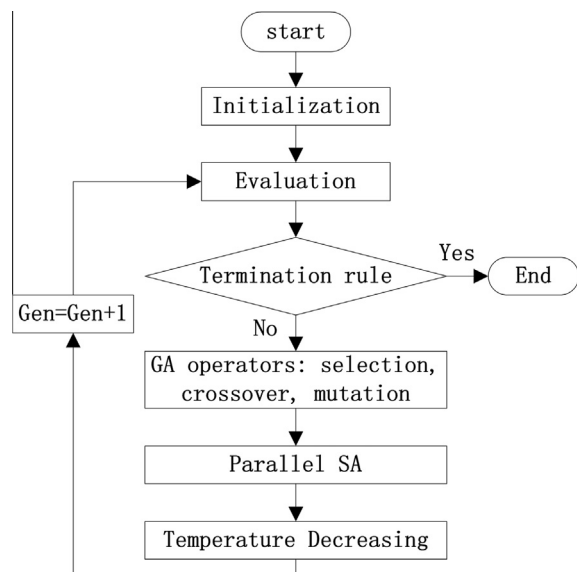

Fig. 4. Genetic algorithm flowchart for chart.

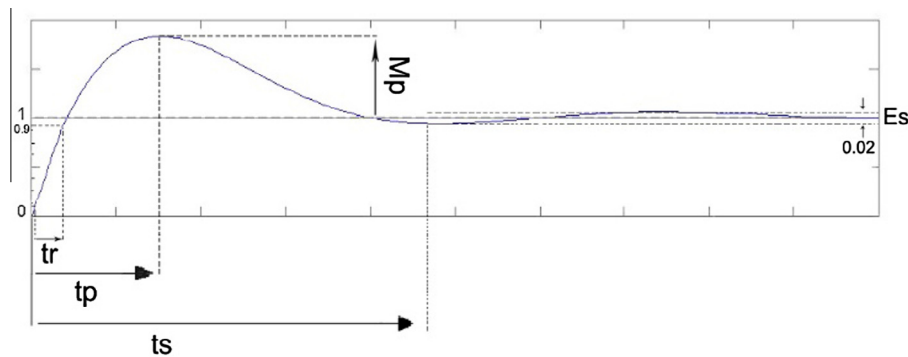

Fig. 5. Computational parameters of measurement standards in the objective function.

Table 1
SSSC and PSS parameters in the state of a 10-percent load increase.

Coefficients		Method		
		No PSS GA-SSSC	PSS GA-SSSC	GA-PSS GA-SSSC
SSSC controller	$K_{P_{\Delta\delta}}$	13.8531	147.7641	190.8186
	$K_{I_{\Delta\delta}}$	0.0019	0.0011	0.0011
	$K_{P_{\Delta\omega}}$	5.5115	55.0737	32.4851
	$K_{I_{\Delta\omega}}$	0.0190	0.0139	0.0096
PSS controller	K_{PSS}	-	0.125	27.3756
	T_{1_PSS}	-	25	7.1209
	T_{2_PSS}	-	0.05	0.0070

$$Fobj = |(100 * ess + 10 * t_s + 1000 * mp)|$$

$$10 \leq K_{I_{\Delta\delta}} \leq 200$$

$$5 \leq K_{I_{\Delta\omega}} \leq 100$$

$$0.0001 \leq K_{P_{\Delta\delta}} \leq 0.002$$

$$0.001 \leq K_{P_{\Delta\omega}} \leq 0.02$$

$$2.1 \leq K_{PSS} \leq 43.37$$

$$0.44 \leq T_{1_PSS} \leq 8.86$$

$$0.001 \leq T_{2_PSS} \leq 0.02$$

(4)

The oscillations existing in the rotor angle deviation and also the rotor frequency velocity are considered as the factors of measurement of the optimization rate in this objective function. In this direction, the rate of the overshoot, the rise time, and the final steady state error with different weights experimentally selected are considered in each of these two standard measurement parameters.

Digital simulation results of sample power system

In this section the validity of the proposed GA algorithm applied on PSS and SSSC controllers is tested on the single infinite machine system in Fig. 1.

However in genetic algorithm the PSS and SSSC controller variables are as below:

$$GA = [K_{P_{\Delta\delta}} \ K_{I_{\Delta\delta}} \ K_{P_{\Delta\omega}} \ K_{I_{\Delta\omega}} \ K_{PSS} \ T_{1_PSS} \ T_{2_PSS}]$$

In order to find the optimal values for the controller variables which are involved in the proposed PI controller system in (3), the optimization objective function is defined as (4), and the constraints are imposed as shown in Fig. 5.

Digital system simulation results with instantaneous load change

In this section, the power system is studied under the influence of a 10-percent instantaneous error load change for 3 cycles. The PSS and SSSC control system parameters are shown in Table 1.

The results illustrated in Fig. 6 show that intense oscillations and longer time are need for damping when the PSS is not present in the system; while, by the entrance of PSS, oscillations are intensely reduced and better results are obtained by optimal regulation

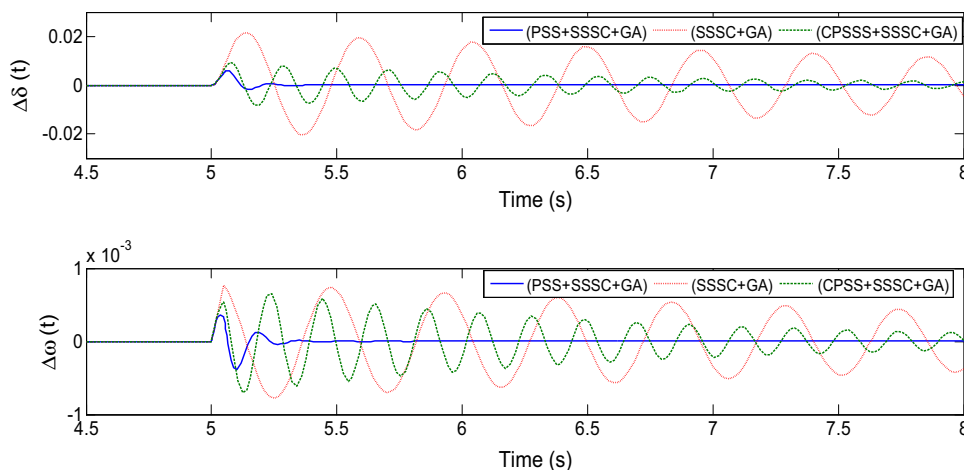

Fig. 6. The response of the rotor angular oscillations and angular frequency of the single-machine system to the 10-percent change in the system load for 3 cycles.

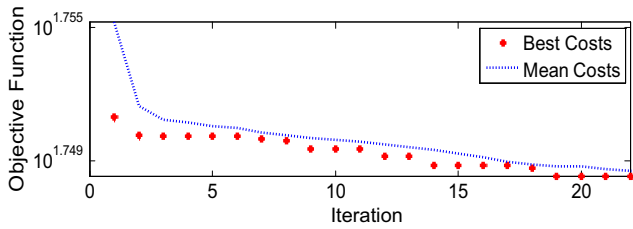

Fig. 7. Process of optimization of the objective function in genetic algorithm for the optimization of the PSS and SSSC control parameters.

Table 2
 10% Step change in load of the power system.

Coefficients	Method			
		No PSS GA-SSSC	PSS GA-SSSC	GA-PSS GA-SSSC
SSSC controller	$K_{P_{\Delta\delta}}$	109.6593	95.9454	192.1895
	$K_{I_{\Delta\delta}}$	6.7218e-004	5.5336e-004	0.0011
	$K_{P_{\Delta\omega}}$	7.7789	14.4295	34.6367
	$K_{I_{\Delta\omega}}$	0.0105	0.0170	0.0049
PSS controller	K_{PSS}	-	0.125	25.8832
	T_{1_PSS}	-	25	6.9150
	T_{2_PSS}	-	0.05	0.0056

of the PSS and SSSC parameters and oscillations are damped in less than half second with a low overshoot.

In genetic algorithm GA-optimization in this paper, the maximum frequency is 30; the number of the elements of each generation is 20; and the displacement coefficients and the shoot are considered to be 0.8 and 0.2, respectively. Fig. 7 illustrates a sample of optimization process and minimization of the objective function.

System simulation results for steady state error

The power system in this section is under the influence of the 10-percent steady state error of load change. The PSS and SSSC control system parameters in this simulation are depicted in Table 2.

The results in Fig. 8, show that the influence of the performance of the SSSC and PSS genetic set is more evident than the others and oscillations are damped in less than a fraction of a second. In this state, it is observed that the rotor angle is subject to a change of the constant value and the rotor angle does not return to its previous state as before. The proposed system was simulated in nominal operation point in [32] while the conventional PI and fuzzy logic controller were applied on the system. The results are shown in Fig. 9 and it is obvious that the effect of proposed GA controlling method on PSS and SSSC controllers is completely better than the results in [32].

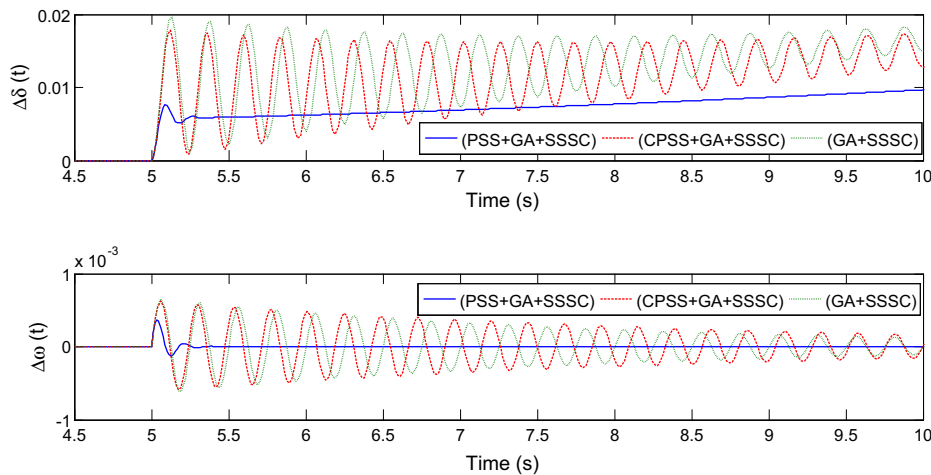

Fig. 8. Response of the rotor angular oscillations and the angular frequency of the single-machine system in the presence of PSS and SSSC to the 10-percent increase in the system load.

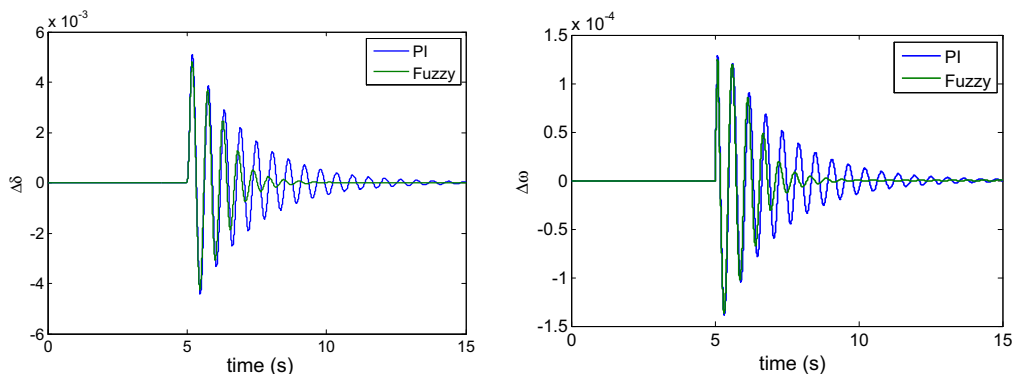

Fig. 9. Response of the rotor angular oscillations and the angular frequency of the single-machine system in [29] to the 10-percent step change in mechanical power which occurs at $t = 5$ s and lasts for 0.1 s.

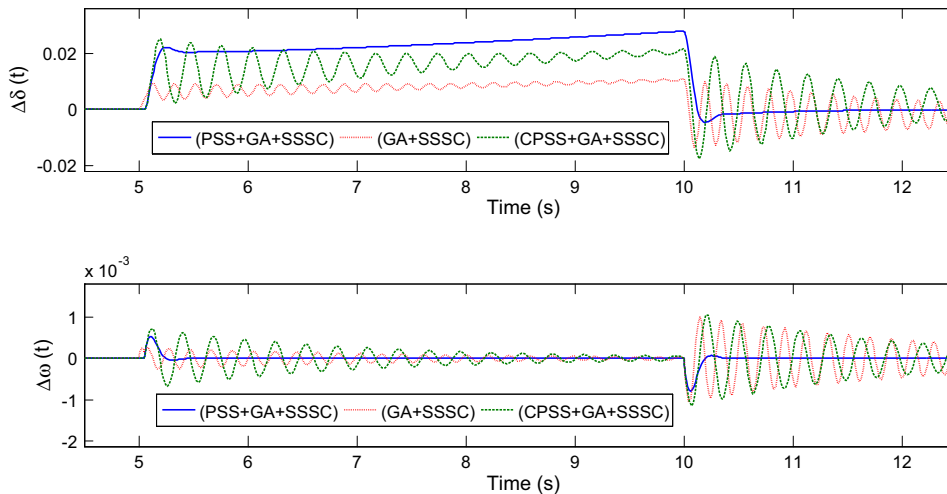

Fig. 10. The response of the rotor angular oscillations and angular frequency of a single-machine system along with PSS and SSSC to the 10-percent increase and decrease of the system load.

Table 3
SSSC and PSS parameters in the presence of a 10-percent load increase and decrease.

Coefficients	Method	Method		
		No PSS GA-SSSC	PSS GA-SSSC	GA-PSS GA-SSSC
SSSC controller	$K_{P_{\Delta\delta}}$	173.9585	69.8172	41.4167
	$K_{I_{\Delta\delta}}$	7.7707e-005	0.0013	0.0017
	$K_{P_{\Delta\omega}}$	27.3212	39.6165	60.0917
	$K_{I_{\Delta\omega}}$	0.0200	0.0163	0.0092
PSS controller	K_{PSS}	-	0.125	26.8559
	T_{1_PSS}	-	25	6.1259
	T_{2_PSS}	-	0.05	0.0068

System simulation results for steady-state load changes

An increase and a decrease in load which permanently appear in the power system are studied at a 10-percent value. Table 3 shows the PSS and SSSC control system parameters obtained from the genetic algorithm along with other values.

As it is observed in Fig. 10, reduction of load is analogous to removing a weight from a stretched string causing more intensive oscillations in the system. In this state, the effect of the PSS and SSSC control set optimized by the genetic algorithm is also clearly observed which confirms the good effect of this control method when confronting the oscillations generated in the network.

Conclusions and extensions

In this paper, a new GA genetic algorithm based control scheme is used to coordinate the actions of power System stabilizer with the FACTS SSSC FACTS device in damping electro-mechanical local modes of oscillations and damping unstable modes triggered by generation-load mismatch as well as fault conditions. The coordinated action of the two SSSC and PSS devices is used by the tuning of action of the added complementary controller. Since optimal regulation of the parameters of these two devices interfere with their performance, creation of optimal control conditions for their performance is therefore of great importance and this was achieved by genetic algorithm GA to optimize the hybrid action of SSSC and PSS to damp the power system unstable and oscillatory electromechanical oscillations which can cause serious and

destructive effects on steady state and dynamic small signal stability of the interconnected power systems.

The results of the dynamic performance of this sample test system under load and fault conditions is studied to validate the Genetic Algorithm Coordinated-Tuning action of the proposed controller.

He same coordinated hybrid action controller can be extended to other use of STATCOM-PSS Dual action for interconnected power systems with renewable Energy Distributed Generation, PV/Wind Farms using a soft Computing search techniques such as PSO, Ant Search, Harmony search techniques.

Appendix A

Information of the model:

$\Delta\delta$	is the synchronous generator rotor angle deviation (in terms of radian)
$\Delta\omega$	is the rotor angular velocity deviation (in terms of radian per second)
ΔP_m	is the rotor input mechanical power deviation
ΔP_e	is the generator power deviation
$\Delta P_D = D$ ($\omega - 1$)	is the very damping index deviation
$\Delta E'_q$	is the generator internal voltage deviation
$\Delta E'_{fd}$	is the generator stimulus voltage deviation

Appendix B

Power System Parameters:

Generator: $M = 2H = 6 \text{ MJ/MVA}$, $D = 0$, $T'_{do} = 5.044 \text{ s}$
 $X_d = 0.1 \text{ pu}$, $X_q = 0.06 \text{ pu}$, $X'_d = 0.025 \text{ pu}$, $f_0 = 60 \text{ Hz}$, $\omega_0 = 2\pi f_0$
 Excitation system: $K_A = 5$, $T_A = 0.005 \text{ s}$
 Transmission line and transformer reactances: $X_{line} = 0.2 \text{ pu}$,
 $X_{TS} = 0.2 \text{ pu}$.

Appendix C

The nominal operating point for the power system is set to the given values [32].

$P_e = 8.0 \text{ pu}$, $Q_e = 0.144 \text{ pu}$, $V_b = 1 \text{ pu}$, $m = 6$.

$K_1 = 1.9014$	$K_2 = 0.6735$	$K_3 = 1.1429$
$k_4 = 0.0498$	$K_5 = -0.0127$	$K_6 = 0.9517$
$K_7 = -0.1759$	$K_8 = 0.0302$	$K_9 = 1.402e^{-4}$
$K_{DCm} = -0.4255$	$K_{pDC} = 0.0244$	$K_{qDC} = 0.0106$
$K_{vDC} = -0.0035$	$K_{pm} = 0.0839$	$K_{qm} = 0.0354$
$K_{vm} = -0.008$		

References

- [1] Kundur P. *Power system stability and control*. N.Y., U.S.A.: Prentice-Hall; 1994.
- [2] Anderson PM, Fouad AA. *Power system control and stability*. IEEE Press; 1997.
- [3] Sharaf AM, Lie TT. A neuro-fuzzy hybrid power system stabilizer. 1994; 30(1): 17–23.
- [4] Larsen EV, Swann DA. Applying power system stabilizers, P-III, practical considerations. *IEEE Trans Power Appl Syst Dec*. 1981;100(6):3034–46.
- [5] Lei X, Lerch EN, Povh D. Optimization and coordination of damping controls for improving system dynamic performance. *IEEE Trans Power Syst Aug*. 2001;16:473–80.
- [6] Sharaf AM, Lie TT, Gooi HB. Neural network based power system stabilizers. In: *Proceedings of the first New Zealand international two-stream conference*; 1993. p. 306–9.
- [7] Gasperic Samo, Mihalic Rafael. The impact of serial controllable FACTS devices on voltage stability. *Int J Electr Power Energy Syst* 2015;64:1040–8.
- [8] Meikandasivam S, Nema Rajesh Kumar, Jain Shailendra Kumar. Power flow control by split TCSC. *Int J Electr Power Energy Syst* 2013;45(1):519–29.
- [9] Kang Bu-Il, Park Jae-Do. Application of thyristor-controlled series reactor for fault current limitation and power system stability enhancement. *Int J Electr Power Energy Syst* 2014;63:236–45.
- [10] Angquist L, Lundin B, Samuelsson J. Power oscillation damping using controlled reactive power compensation – a comparison between series and shunt approaches. *IEEE-PES 92 winter meeting*, Paper 5 39-7 PWRS.
- [11] Panda S, Padhy NP, Patel RN. Power system stability improvement by PSO optimized SSSC-based damping controller. *Electr Power Compon Syst* 2008;36.
- [12] Zamora-Cárdenas EA, Alcaide-Moreno BA, Fuerte-Esquivel CR. STATE estimation of flexible AC transmission systems considering synchronized phasor measurements. *Electr Power Syst Res* 2014;106:120–33.
- [13] Varma RK, Auddy S, Semsedini Y. Mitigation of subsynchronous resonance in a series-compensated wind farm using FACTS controllers. *IEEE Trans Power Deliv* 2008;23(3):1645–54.
- [14] Chen X, Pahalawaththa N, Annakkage U, Kumble C. Controlled series compensation for improving stability of multi-machine power systems. *IEE Proc Gen Trans Distrib* 1995;142(4):361–6.
- [15] Wang HF. Static synchronous series compensator to damp power system oscillations. *Electr Power Syst Res* 2000;54(2):113–9.
- [16] Falehi AD, Rostami M, Doroudi A. Coordinated design of PSSs and SSSC based damping controller based on GA optimization technique for damping of power system multi-mode oscillations. In: *Power electronics, drive systems and technologies conference (PEDSTC)*, 2011 2nd. p. 199–204.
- [17] Nambu M, Ohsawa Y. Development of an advanced power system stabilizer using a strict linearization approach. *IEEE Trans Power Syst* 1996;11(2):813–8.
- [18] Larsen EV, Swann DA. Applying power system stabilizers Part II: Performance objectives and tuning concepts. *IEEE Trans Power Apparatus Syst* 1981;100(6):3025–33.
- [19] Gyugyi L, Schauder CD, Sen KK. Static synchronous series compensator: a solid-state approach to the series compensation of transmission lines. *IEEE Trans Power Deliv* 1997;12(1):406–17.
- [20] Castro MS, Ayres HM, Da Costa VF, da LCP. Impacts of the SSSC control modes on small-signal and transient stability of a power system. *Electr Power Syst Res* 2007;77(1):1–9.
- [21] Sharaf AM, Lie TT. A robust nonlinear power system stabilizer. In: *Proceedings of the 38th Midwest symposium on circuits and systems*, vol. 2; 1995. p. 1098–101.
- [22] Madani V, Fitch J, Skok S, Begovic MM, Phadke A. Wide-area monitoring, protection, and control of future electric power networks. *Proc IEEE* 2011;99(1):80–93.
- [23] Panda S, Padhy NP. Comparison of particle swarm optimization and genetic algorithm for FACTS-based controller design. *Appl Soft Comput* 2008;8(4):1418–27.
- [24] Panda S, Padhy NP. Optimal location and controller design of STATCOM using particle swarm optimization. *J Franklin Inst* 2008;345:166–81.
- [25] Abido MA. Analysis and assessment of STATCOM-based damping stabilizers for power system stability enhancement. *Int J Electr Power Energy Syst* 2005;73:177–85.
- [26] Panda S. Differential evolutionary algorithm for TCSC-based controller design. *Simul Model Pract Theory* 2009;17(10):16181634.
- [27] Padhy BP, Srivastava SC, Verma NK. Robust wide-area TS fuzzy output feedback controller for enhancement of stability in multimachine power system. *IEEE Syst J* 2012;6(3):426–35.
- [28] Ladjavardi M, Masoum MAS. Application of multi-objective genetic algorithm for optimal design of SSSC based robust damping controllers to improve small signal stability. In: *Power systems conference and exposition*, 2006. PSCE'06, 2006 IEEE PES, 2006. p. 2124–30.
- [29] Rai D, Faried SO, Ramakrishna G, Edris A. Damping inter-area oscillations using phase imbalanced series compensation schemes. *IEEE Trans Power Syst* 2011;26(3):1753–61.
- [30] Jeelani Basha G, Narasimhulu N, Malleswara Reddy P. Improvement of small signal stability of a single machine infinite bus using SSSC equipped with a hybrid fuzzy logic controller. *Int J Adv Res Electr Electron Instru Eng* 2014;3(2).
- [31] Haupt RL, Haupt SE. *Practical genetic algorithms*. New York: John Wiley & Sons Inc.; 2004.
- [32] Golshannavaz S, Farsadi M, Nazarpour D. Low frequency oscillations damping by static synchronous series compensator equipped with an auxiliary fuzzy logic controller. In: *19 th Iranian conference on electrical engineering (ICEE)*; 2011. p. 1–6.
- [33] Magaji N, Mustafa MW, Muda Z. Power system damping using GA based fuzzy controlled TCSC device. *Sci Res Essays* 2011;6(27):5671–84.