

Simulink / MATLAB Dynamic Induction Motor Model for use in Undergraduate Electric Machines and Power Electronics Courses

A.W. Leedy, Member, IEEE
Department of Engineering & Physics
Murray State University
131 Blackburn Science Building
Murray, KY 42071-3346
aleedy@murraystate.edu

Abstract— A dynamic model of the induction motor developed using Simulink / MATLAB that is beneficial for use in undergraduate electric machines and power electronics courses is presented. The model can be used to study the dynamic behavior of the induction motor, or can be used in various motor-drive topologies with minor modifications. The motor model presented is based on the T-type d-q model of the induction motor. A block model approach is used in the construction of the motor model that will allow students to resolve reference frame theory issues. The model developed is intuitive, easy to use, and allows all motor parameters to be easily accessed for monitoring and comparison purposes. The model presented is capable of being used with various inverter topologies and PWM schemes with minor modifications.

Keywords - *Dynamic Model; Inverter; Induction Motor.*

I. INTRODUCTION

In electric drive studies, the transient behavior of an electric machine is very important. The transient behavior is of particular importance when the drive system is to be controlled [1]. A dynamic model of a machine leads to insight into the electrical transients [2]. Simulink allows electrical engineers to model dynamical systems with ease using a block diagram approach that can be constructed fast and efficiently. There are many Simulink induction motor models in the literature [3]. However, most of them do not give details as to how the model equations and subsystems within the model are derived.

Computer-aided teaching tools are necessary to effectively teach electric machines and power electronics courses. The use of PSPICE and MATLAB/Simulink software packages are critical in teaching electric machines and power electronics due to the complexity of the circuits involved and the waveforms generated by the circuits. It has been shown that PSPICE and MATLAB/Simulink can be used effectively to teach power electronics to large groups with various educational backgrounds [4]. The use of PSPICE and

MATLAB/Simulink can also provide a broad platform for students to extend their basic skills.

Capturing the attention of college students has become more difficult in this age of laptop computers, text messaging, and various social media outlets. Most students in this generation prefer new, exciting, and innovative methods of lecturing. In order to provide a high-tech learning environment that today's students crave, it is necessary to use software packages in the classroom that will enhance the lecture process by stimulating visual interest and effects.

The purpose of this paper is to present a dynamic model of the induction motor developed using Simulink / MATLAB that can be used to study the transient behavior of a motor-drive system such as the one shown in Fig. 1. In this figure, a DC voltage source is connected to a three-phase inverter driving a three-phase induction motor with a load attached. In Fig. 1, V_i is the inverter DC input voltage and I_i is the inverter DC input current. The goal of this paper is to develop a model that is intuitive, easy to use, and that will allow access to all motor parameters for monitoring and comparison purposes.

A model of the induction motor and other electric machine models are available in the Simulink Power System Blockset. However, these models provide access to a limited number of machine parameters. For researchers and teachers with limited budgets, building a dynamic model of an induction motor or other electric machine using basic Simulink blocks is a cost effective approach to studying the dynamic behavior of an electric machine. The Simulink Power System Blockset is an extra toolbox that does not come with the student version or full version of MATLAB / Simulink. Toolboxes that are not included as standard with MATLAB / Simulink are an added cost that professors at teaching focused universities may not be able to afford.

The cost savings is not the only advantage of building your own dynamic model of a particular electric machine. Students learn more if they have to build a model from equations instead of just "dragging and dropping" a Simulink

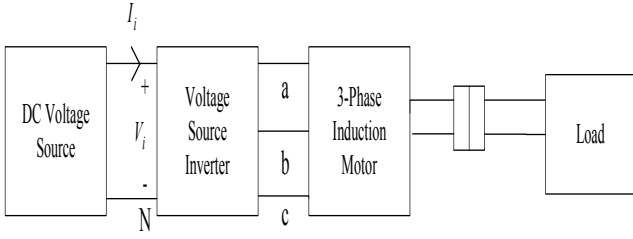

Fig. 1. Motor-Drive System Model.

motor part into the Simulink work space. By using the differential equations that describe the operation of a particular motor-drive system, students have to develop the mathematical model of the system before working on the Simulink model.

II. INDUCTION MOTOR DYNAMIC MODEL

All analysis and simulation in this paper are based on the d-q or dynamic equivalent circuit of the induction motor represented in the rotating reference frame [5, 6] shown in Fig. 2. It should be noted that all quantities in Fig. 2 have been referred to the stator. For the interested reader, a paper that includes the steady-state T-type equivalent circuit model of the induction motor can be found in [7].

The differential equations produced from analysis of the circuits in Fig. 2 are as follows:

$$v_{ds} = R_s i_{ds} + \frac{d\lambda_{ds}}{dt} - \omega_e \lambda_{qs}, \quad (1)$$

$$v_{qs} = R_s i_{qs} + \frac{d\lambda_{qs}}{dt} + \omega_e \lambda_{ds}, \quad (2)$$

$$v_{dr} = 0 = R_r i_{dr} + \frac{d\lambda_{dr}}{dt} - (\omega_e - \omega_r) \lambda_{qr}, \quad (3)$$

and

$$v_{qr} = 0 = R_r i_{qr} + \frac{d\lambda_{qr}}{dt} + (\omega_e - \omega_r) \lambda_{dr} \quad (4)$$

where d is the direct axis, q is the quadrature axis, v_{ds} is the d -axis stator voltage, v_{qs} is the q -axis stator voltage, v_{dr} is d -axis rotor voltage, v_{qr} is q -axis rotor voltage, i_{ds} is the d -axis stator current, i_{qs} is the q -axis stator current, i_{dr} is d -axis rotor current, i_{qr} is q -axis rotor current, R_s is the stator resistance, R_r is the rotor resistance, ω_e is the angular velocity of the reference frame, ω_r is the angular velocity of the rotor, and λ_{ds} , λ_{qs} , λ_{dr} , and λ_{qr} are flux linkages. It is assumed that the induction motor analyzed is a squirrel cage machine, leading to the rotor voltage in (3) and (4) being zero. The flux linkages in (1-4) can be written as:

$$\lambda_{ds} = L_s i_{ds} + L_m i_{dr}, \quad (5)$$

$$\lambda_{qs} = L_s i_{qs} + L_m i_{qr}, \quad (6)$$

$$\lambda_{dr} = L_r i_{dr} + L_m i_{ds}, \quad (7)$$

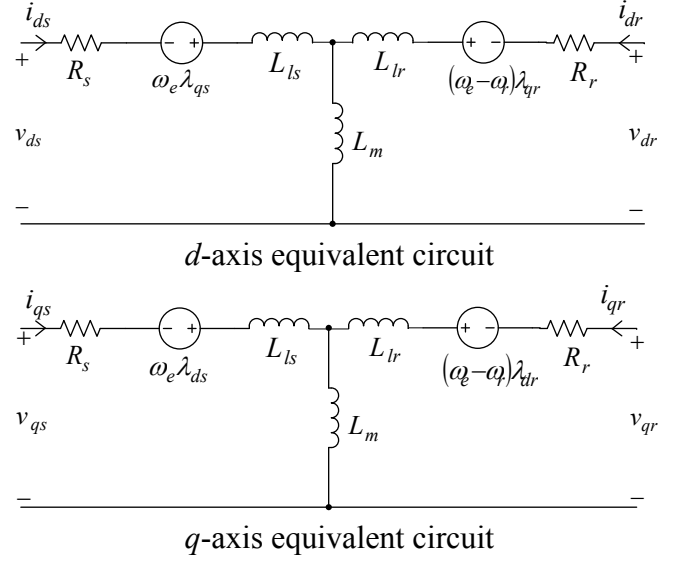

Fig. 2. d-q equivalent circuit of the Induction Motor. and

$$\lambda_{qr} = L_r i_{qr} + L_m i_{qs} \quad (8)$$

where L_r is the rotor self inductance, L_s is the stator self inductance, L_m is the magnetizing inductance, L_{lr} is the rotor leakage inductance, and L_{ls} is the stator leakage inductance. The self inductances in (5-8) can be expressed as:

$$L_s = L_m + L_{ls} \quad (9)$$

and

$$L_r = L_m + L_{lr}. \quad (10)$$

The currents can be written as:

$$i_{ds} = \frac{\lambda_{ds} - L_m i_{dr}}{L_s}, \quad (11)$$

$$i_{qs} = \frac{\lambda_{qs} - L_m i_{qr}}{L_s}, \quad (12)$$

$$i_{dr} = \frac{\lambda_{dr} - L_m i_{ds}}{L_r}, \quad (13)$$

and

$$i_{qr} = \frac{\lambda_{qr} - L_m i_{qs}}{L_r}. \quad (14)$$

After making substitutions, the currents can be expressed in terms of flux linkages as:

$$i_{ds} = \frac{L_r}{L_r L_s - L_m^2} \lambda_{ds} - \frac{L_m}{L_r L_s - L_m^2} \lambda_{dr}, \quad (15)$$

$$i_{qs} = \frac{L_r}{L_r L_s - L_m^2} \lambda_{qs} - \frac{L_m}{L_r L_s - L_m^2} \lambda_{qr}, \quad (16)$$

$$i_{dr} = \frac{L_s}{L_r L_s - L_m^2} \lambda_{dr} - \frac{L_m}{L_r L_s - L_m^2} \lambda_{ds}, \quad (17)$$

and

$$i_{qr} = \frac{L_s}{L_r L_s - L_m^2} \lambda_{qr} - \frac{L_m}{L_r L_s - L_m^2} \lambda_{qs}. \quad (18)$$

The electromagnetic torque of the machine can be written as:

$$T_e = \frac{3}{2} \frac{P}{2} L_m [i_{qs} i_{dr} - i_{ds} i_{qr}] \quad (19)$$

where P is the number of poles and T_e is the electromagnetic torque. Neglecting mechanical damping, the torque and rotor speed are related by:

$$\frac{d\omega_r}{dt} = \frac{P}{2J} (T_e - T_L) \quad (20)$$

where T_L is the load torque and J is the inertia of the rotor and connected load. The angle θ_e is calculated directly by integrating the frequency of the input voltages as:

$$\theta_e = \int_0^t \omega_e dt + \theta_e(0) \quad (21)$$

where $\theta_e(0)$ is the initial rotor position.

Three-phase voltages can be converted to the two-phase stationary frame using the following relationship:

$$\begin{bmatrix} v_{qs}^s \\ v_{ds}^s \end{bmatrix} = \begin{bmatrix} 1 & 0 & 0 \\ 0 & -\frac{1}{\sqrt{3}} & \frac{1}{\sqrt{3}} \end{bmatrix} \begin{bmatrix} v_{an} \\ v_{bn} \\ v_{cn} \end{bmatrix} \quad (22)$$

where the superscript s in (22) refers to the stationary frame. The voltages can be converted from the two-phase stationary frame to the synchronously rotating frame using the following:

$$v_{qs} = v_{qs}^s \cos \theta_e - v_{ds}^s \sin \theta_e, \quad (23)$$

and

$$v_{ds} = v_{qs}^s \sin \theta_e + v_{ds}^s \cos \theta_e. \quad (24)$$

The current variables can be found as:

$$i_{qs}^s = i_{qs} \cos \theta_e + i_{ds} \sin \theta_e, \quad (25)$$

$$i_{ds}^s = -i_{qs} \sin \theta_e + i_{ds} \cos \theta_e, \quad (26)$$

and

$$\begin{bmatrix} i_a \\ i_b \\ i_c \end{bmatrix} = \begin{bmatrix} 1 & 0 \\ -\frac{1}{2} & -\frac{\sqrt{3}}{2} \\ -\frac{1}{2} & \frac{\sqrt{3}}{2} \end{bmatrix} \begin{bmatrix} i_{qs}^s \\ i_{ds}^s \end{bmatrix}. \quad (27)$$

III. MATLAB / SIMULINK MODEL

The approach used to build the Simulink model in this paper is a block type or modular approach. The approach is based on the idea presented in [8]. However, the goal of this paper is to present the model in a clear and simplified manner that is geared toward undergraduate electric machines and power electronics students. This paper also examines different types of simulations and analyses not covered in [8].

To begin the construction of the Simulink model of the induction motor, (11-14) can be substituted into (1-4), producing the following differential equations written in terms of flux linkages:

$$\frac{d\lambda_{ds}}{dt} = v_{ds} - \frac{R_s L_r}{L_r L_s - L_m^2} \lambda_{ds} + \frac{R_s L_m}{L_r L_s - L_m^2} \lambda_{dr} + \omega_e \lambda_{qs}, \quad (29)$$

$$\frac{d\lambda_{qs}}{dt} = v_{qs} - \frac{R_s L_r}{L_r L_s - L_m^2} \lambda_{qs} + \frac{R_s L_m}{L_r L_s - L_m^2} \lambda_{qr} - \omega_e \lambda_{ds}, \quad (30)$$

$$\frac{d\lambda_{dr}}{dt} = \frac{-R_r L_s}{L_r L_s - L_m^2} \lambda_{dr} + \frac{R_r L_m}{L_r L_s - L_m^2} \lambda_{ds} + (\omega_e - \omega_r) \lambda_{qr}, \quad (31)$$

and

$$\frac{d\lambda_{qr}}{dt} = \frac{-R_r L_s}{L_r L_s - L_m^2} \lambda_{qr} + \frac{R_r L_m}{L_r L_s - L_m^2} \lambda_{qs} - (\omega_e - \omega_r) \lambda_{dr}. \quad (32)$$

The Simulink model can now be constructed by creating Simulink subsystems using (5-8), (9, 10), (15-27), and (29-32). Each Simulink subsystem solves one of the model equations in an easy to understand manner. The subsystem is constructed using basic Simulink blocks such as the integrator, gain, sum, etc. The basic Simulink blocks are standard on all versions of MATLAB; including the student version. Using basic Simulink blocks avoids having to purchase extra toolboxes such as the SimPowerSystems

toolbox that requires extra expenses that would be added to research or educational budgets.

The subsystem that implements (29) is shown in Figure 3. Implementation of (30-32) in Simulink can be achieved in the same manner as in Fig. 3. The subsystem that implements (19) is shown in Fig. 4. The subsystem that implements (27) is shown in Fig. 5. The Kabc matrix shown in the matrix gain block in Fig. 5 is the transform matrix from two-phase stationary frame currents to the three-phase *abc* frame. This matrix can be defined in the MATLAB editor, the *m* file can be saved, and the Simulink model of the motor can be simulated by running the *m* file.

Implementation of (22) is similar to (27) except that the transform matrix from three-phase voltages to the two-phase stationary frame in (22) must be defined in the MATLAB editor. The subsystem that implements (15) is shown in Fig. 6. Implementation of (16-18) in Simulink can be achieved in the same manner as in Fig. 6. The subsystem that implements (20) is shown in Fig. 7. Implementation of (21), and (23-26) can be achieved using basic Simulink blocks. The trigonometric function block must be used in (23-26) for the sine and cosine functions. After all of the induction motor model equations have been implemented in Simulink, all of the subsystems must be tied together to produce the main “upper level” system that will complete the implementation of the Simulink induction motor model. The upper level system is shown in Fig. 8. A double click on any of the blocks in Fig. 8 within the Simulink workspace will pull up a subsystem within each individual block shown in Fig. 8. The Simulink model presented could also be thought of as being built in layers.

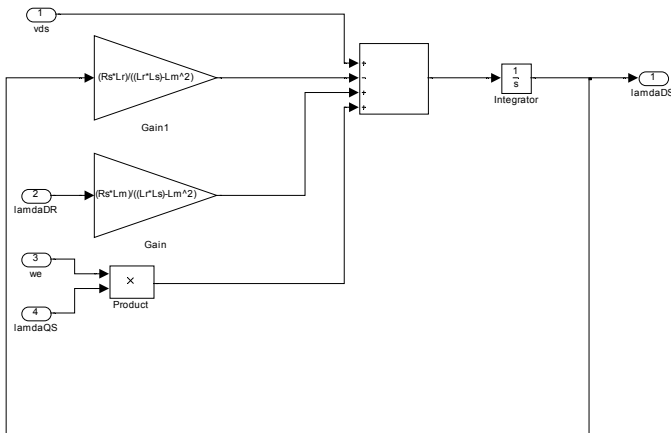

Fig. 3. Subsystem that implements (29) in Simulink.

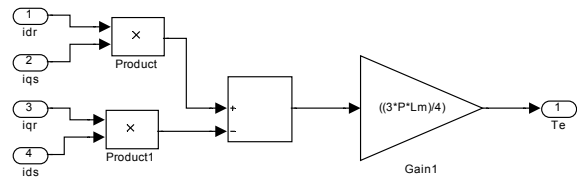

Fig. 4. Subsystem that implements (19) in Simulink.

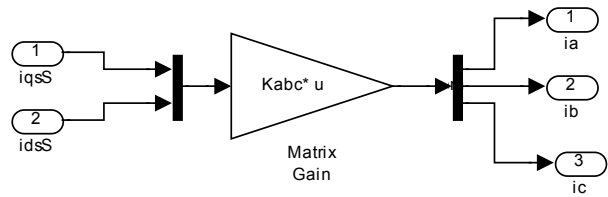

Fig. 5. Subsystem that implements (27) in Simulink.

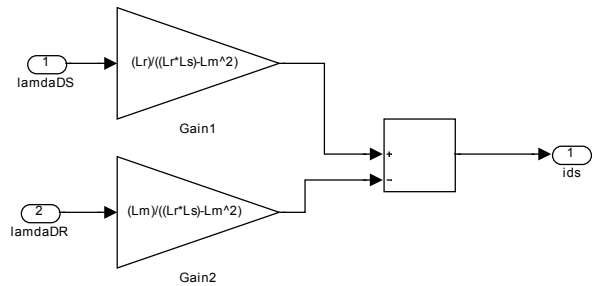

Fig. 6. Subsystem that implements (15) in Simulink.

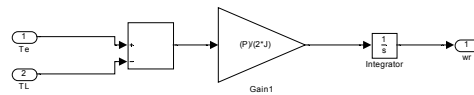

Fig. 7. Subsystem that implements (20) in Simulink.

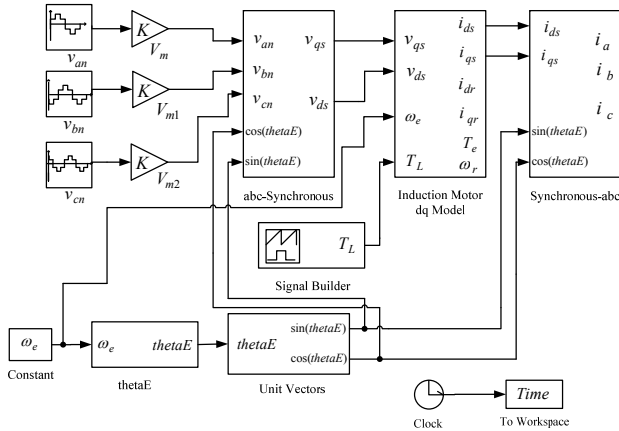

Fig. 8. Simulink Induction Motor Model.

VI. SIMULATION RESULTS

The system shown in Fig. 1 was simulated using the Simulink induction motor model shown in Fig. 8. The inverter shown in Fig. 1 was operating as a six-step voltage source inverter with 180° conduction and a DC input voltage to the inverter of $V_i=460\text{V}$ during the simulation. A plot of the phase a line-to-neutral voltage at the input terminals of the induction motor during the simulation is shown in Fig. 9. The parameters of the motor shown in Fig. 1 were: $R_1=0.087\Omega$, $R_2=0.228\Omega$, $L_m=34.7\text{mH}$, $L_{ls}=0.8\text{mH}$, $L_{lr}=0.8\text{mH}$, $J=1.662\text{kg m}^2$, $P=4$, and $HP=50$. The load applied to the motor during simulations was a pulsed torque load with the following characteristics: $T_L=80\text{N-m}$, $T=10\text{s}$, and $D=4/5$. To verify the induction motor Simulink model results, a PSPICE model of the system shown in Fig. 1 was simulated. During PSPICE simulation tests, motor parameters, load conditions, etc. were the same as the Simulink model.

Fig. 10 shows the load torque and the angular velocity of the rotor using the Simulink model. Fig. 11 shows the electromagnetic torque and the phase a stator current produced using the Simulink model. The PSPICE simulation results for the load torque and the angular velocity of the rotor are shown in Fig. 12. Fig. 13 shows the PSPICE simulation results for the electromagnetic torque and the phase a stator current. It can be observed from Fig. 10-13 that the Simulink model results and PSPICE model results closely match each other. This verifies that the Simulink induction motor model shown in Fig. 8 is a valid model that can be used for various induction motor studies. The model shown in Fig. 8 was simulated again with all parameters the same except that the load torque was changed to $T_L=160\text{N-m}$, $T=10\text{s}$, and $D=4/5$. The motor is operating at 75% of full load with 160N-m of load torque applied. The results are shown in Fig. 14 and Fig. 15.

VII. CONCLUSIONS

A dynamic model of the induction motor developed using Simulink / MATLAB that is beneficial for use in

undergraduate electric machines and power electronics courses has been presented. A block model approach was used in the construction of the motor model that allows students to resolve reference frame theory issues. The model developed is intuitive, easy to use, and allows all motor parameters to be easily accessed for monitoring and comparison purposes. The model can be used to study the dynamic behavior of the induction motor, or can be used in various motor-drive topologies with minor modifications. New subsystems can be added to the model presented to implement various types of control schemes. The model presented is also capable of being used with various inverter topologies and PWM schemes with minor modifications.

VIII. REFERENCES

- [1] K.S. Graeid, H.W. Ping, and H.A.F. Mohamed, "Simulink Representation of Induction Motor Reference Frames," in *Proceedings of the 2009 International Conference for Technical Postgraduates (TECHPOS)*, 2009, pp. 1-4.
- [2] O. Dordevic, N. Bodo, and M. Jones, "Model of an Induction Machine with an Arbitrary Phase Number in MATLAB / Simulink for Educational Use," in *Proceedings of the 2010 International Universities Power Engineering Conference (UPEC)*, 2010, pp. 1-6.
- [3] O. D. Momoh, "Dynamic Simulation of Cage Rotor Induction Machine – A Simplified and Modular Approach," in *Proceedings of the 44th IEEE Southeastern Symposium on System Theory*, 2012, pp. 200-203.
- [4] Bellur, D.M. and Kazimierczuk, M.K., "PSPICE and MATLAB Applications in Teaching Power Electronics to Graduate Students at Wright State University," in *Proceedings of the 2008 ASEE North Central Section Conference*, 2008.
- [5] P.C. Krause, O. Wasynczuk, and S.D. Sudhoff, *Analysis of Electric Machinery*, IEEE Press, NY: 1995.
- [6] T.A. Lipo, "Electric Machine Analysis and Simulation," Research Report, Wisconsin Electric Machines & Power Electronics Consortium, 2000, pp. 313-324.
- [7] A.W. Leedy and R.M. Nelms "Simplified Model of an Inverter-Fed Induction Motor for the Analysis of a DC Power System", in *Proceedings of the 36th IEEE Southeastern Symposium on System Theory*, 2004, pp. 275-279.
- [8] B. Ozpineci and L.M. Tolbert, "Simulink Implementation of Induction Machine Model-A Modular Approach," in *Proceedings of the IEEE International Electric Machines and Drives Conference (IEMDC)*, 2003, pp. 728-734.

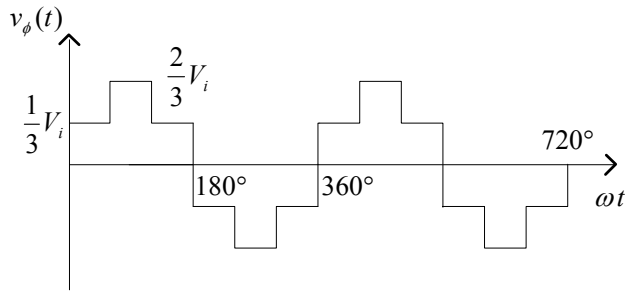

Fig. 9. Six-Step Phase *a* Line-to-Neutral Voltage Waveform.

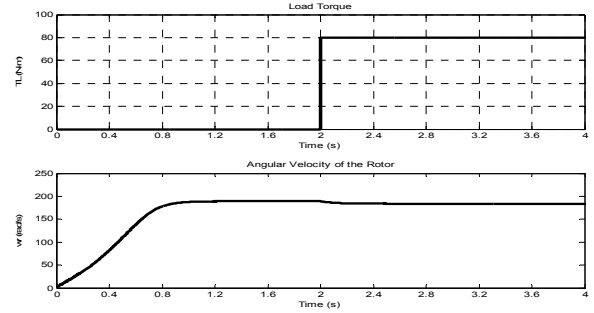

Fig. 12. PSPICE Load Torque and Rotor Angular Velocity Plots.

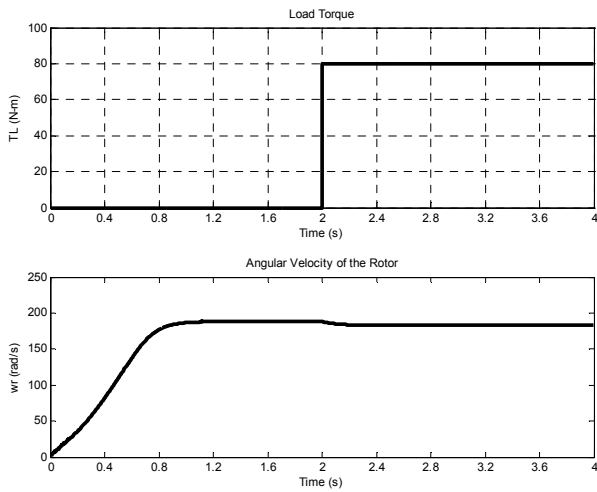

Fig. 10. Simulink Load Torque and Rotor Angular Velocity Plots.

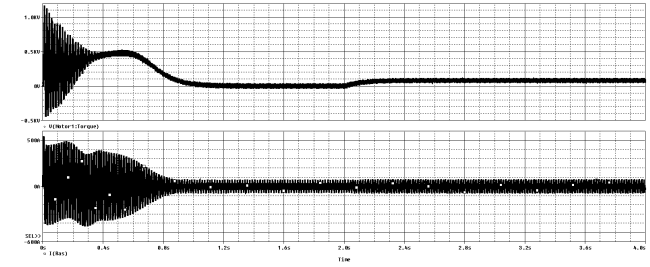

Fig. 13. PSPICE Electromagnetic Torque and Stator Current Plots.

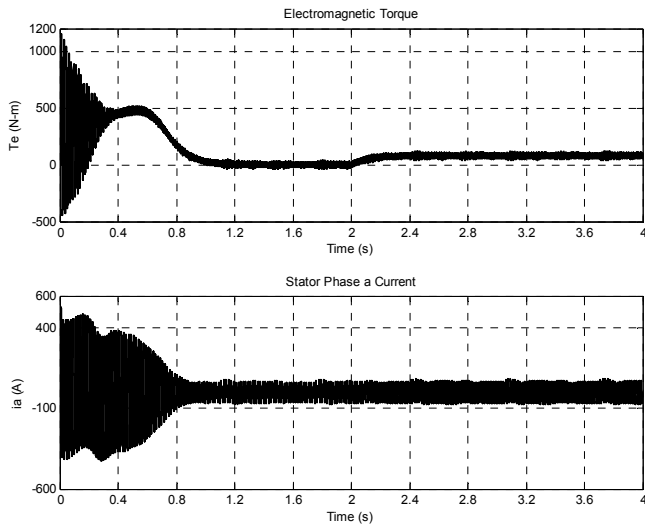

Fig. 11. Simulink Electromagnetic Torque and Stator Current Plots.

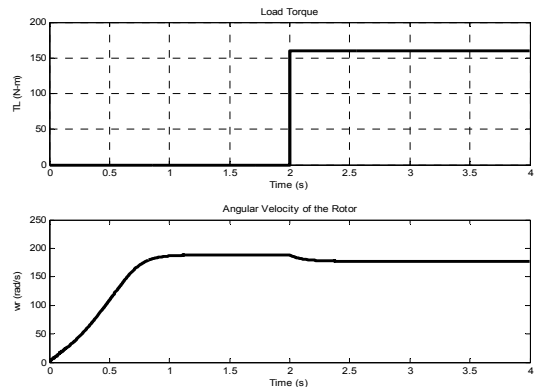

Fig. 14. Simulink Load Torque and Rotor Angular Velocity Plots at 75% of Full Load.

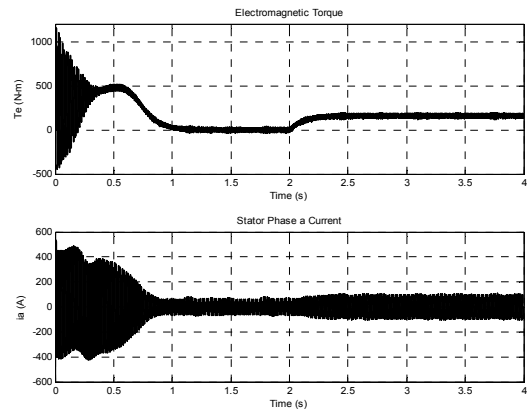

Fig. 15. Simulink Electromagnetic Torque and Stator Current Plots at 75% of Full Load.