

# Reactive Power Compensation for Integration of Wind Power in a Distribution Network

Shahzad Ahsan  
 F/o Engg. & Technology  
 Jamia Millia Islamia  
 New Delhi, India

Anwar Shahzad Siddiqui  
 F/o Engg. & Technology  
 Jamia Millia Islamia  
 New Delhi, India

Shagufta Khan  
 F/o Engg. & Technology  
 Jamia Millia Islamia  
 New Delhi, India

**Abstract**—As a promising renewable alternative, the wind power is highly expected to contribute a significant part of generation in power systems in the future, but this also bring new integration related power quality issues, which mainly consist of voltage regulation and reactive power compensation. Wind power, as a rule, does not contribute to voltage regulation in the system. Induction machines are mostly used as generators in wind power based generations. Induction generators draw reactive power from the system to which they are connected. Therefore, the integration of wind power to power system networks; especially a weak distribution networks is one of the main concerns of the power system engineers. Voltage control and reactive power compensation in a weak distribution networks for integration of wind power represent main concern of this paper. The problem is viewed from MATLAB/Simulink simulation of weak distribution network and wind power integration in this network. Without reactive power compensation, the integration of wind power in a network causes voltage collapse in the system and under-voltage tripping of wind power generators. For dynamic reactive power compensation, when, STATCOM (Static Synchronous Compensator) is a used at a point of interconnection of wind farm and the network; the system absorbs the generated wind reactive power while maintaining its voltage level.

**Keywords**- Induction generators; Non-linear dynamic simulation; Reactive power compensation; STATCOM; Voltage regulation.

## I. INTRODUCTION

The Indian wind energy sector has an installed capacity of 14158.00 MW (as on March 31, 2011). In terms of wind power installed capacity, India is ranked 5th in the World. Today India is a major player in the global wind energy market.

The potential is far from exhausted. Indian Wind Energy Association has estimated that with the current level of technology, the ‘on-shore’ potential for utilization of wind

energy for electricity generation is of the order of 65,000 MW. The unexploited resource availability has the potential to sustain the growth of wind energy sector in India in the years to come. Recently, Government of India has deregularized the power sector. Ministry of New and Renewable Energy (MNRE) has issued guidelines to all state governments to create an attractive environment for the export, purchase, wheeling and banking of electricity generated by wind power projects. Hence, sustainable growth of wind power generation is expected in the years to come [1].

This growth of wind power generation is likely to influence the operation and planning of the existing power system networks. Because integration of wind power in a power systems resents problem of voltage regulation and reactive power compensation [2].

The wind turbines are composed of an aerodynamic rotor, a mechanical transmission system, squirrel cage induction generator, a control system, limited reactive power compensation and a step-up transformer. The conventional wind turbine is even at the present time, the most common type of wind turbine installed.

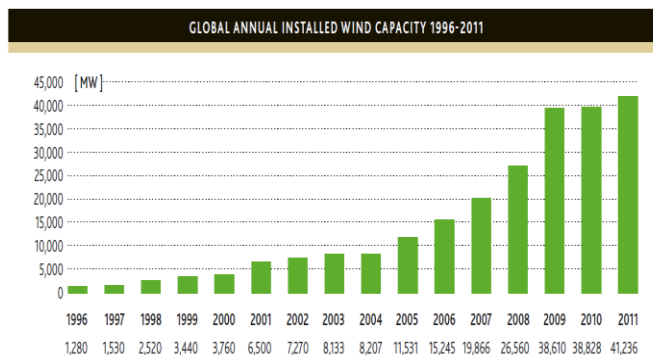
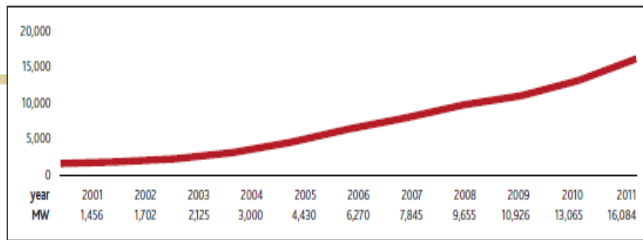

Fig. 1. Global annual installed capacity growth from 1996 to 2011

Total Installed capacity



Source: GWEC

Fig. 2. Year wise installed capacity (MW) in India

Therefore, this paper deals about such conventional squirrel cage induction generator system. An important operating characteristic of the squirrel cage induction generator is that this type of generator always consumes reactive power, which is undesirable for the transmission system. Particularly in the case of large turbines and weak distribution system.

Another characteristic of the squirrel cage induction generators is that, in general, this type of generator tends to slow down voltage restoration after a voltage collapse and this can lead to voltage and rotor speed instability. When the voltage restores, the generator will consume reactive power, impeding the voltage restoration. When the voltage does not return quickly enough, the generator continues to accelerate and consumes even larger amount of reactive power [2]. This process eventually leads to voltage and rotor speed instability if the wind turbine is connected to a weak system.

To prevent these types of instabilities; conventionally, shunt capacitor banks are connected at the generator terminals to compensate its reactive power consumption [3]. To minimize the reactive power exchange between wind farms and distribution network, dynamic compensation of reactive power can be employed [4].

Power electronics based FACTS devices such as SVC and STATCOM are useful for dynamic compensation of reactive power. The STATCOM performs the same function as the SVC. However at voltages lower than the normal voltage regulation range, the STATCOM can generate more reactive power than the SVC. This is due to the fact that the maximum capacitive power generated by a SVC is proportional to the square of the system voltage (constant susceptance) while the maximum capacitive power generated by a STATCOM decreases linearly with voltage (constant current) [5]. This ability to provide more capacitive reactive power during voltage collapse is one important advantage of the STATCOM over the SVC. In addition, the STATCOM will normally exhibit a faster response than the SVC because with the VSC, the STATCOM has no delay associated with the thyristor firing. In his paper the reactive power compensation capability of STATCOM for wind power integration into a weak distribution network is evaluated. The study is based on the three phase non-linear dynamic simulation, utilizing the Simpower system blockset for the use with MATLAB/Simulink [6].

## II. MODEL DESCRIPTION

Three pairs of 1.5 MW wind-turbines has been used. Wind turbines use squirrel-cage induction generators (SCIG). The stator winding is connected directly to distributed network. A wind farm consisting of six 1.5-MW wind turbines is connected to a 25-kV distribution system exports power to a 120-kV grid through a 25-km 25-kV feeder. The 9-MW wind farm is simulated by to the 50 Hz grid and the rotor is driven by a variable-pitch wind turbine. The pitch angle is controlled in order to limit the generator output power at its nominal value for winds exceeding the nominal speed (9 m/s). In order to generate power the IG speed must be slightly above the synchronous speed. Speed varies approximately between 1pu at no load and 1.005 pu at full load. Each wind turbine has a protection system monitoring voltage, current and machine speed. Reactive power absorbed by the SCIGs is partly compensated by capacitor banks connected at each wind turbine low voltage bus (400 kvar for each pair of 1.5 MW turbine). The rest of reactive power required to maintain the 25-kV voltage at B25 bus close to 1pu is provided by a 3-Mvar STATCOM with a 3% droop setting. The turbine mechanical power as function of turbine speed is displayed for wind speeds ranging from 4 m/s to 10 m/s. The nominal wind speed yielding the nominal mechanical power (1pu=3 MW) is 9 m/s. The wind turbine model (from the DR library) and the STATCOM model (from the FACTS library) are phasor models that allow transient stability type studies with long simulation times. In this paper, the system is observed during 20 s.

The wind speed applied to each turbine is controlled by the "Wind 1" to "Wind 3" blocks. Initially, wind speed is set at 8 m/s, then starting at t=2s for "Wind turbine 1", wind speed is rammed to 11 m/s in 3 seconds. The same gust of wind is applied to Turbine 2 and Turbine 3, respectively with 2 seconds and 4 seconds delays. Then, at t=15 s a temporary line to ground fault is applied at the low voltage terminals (575 V) of "Wind Turbine 2".

## III. SIMULATION OF MODEL

Distribution systems are inherently unbalanced in most of the cases due to the asymmetrical line spacing and imbalance of consumer load. In view of this, single phase models cannot be used for accurate studies on the operation of distribution systems[4]. Therefore in this work all network components are represented by the three phase models.

Simulation model is simulated in MATLAB/Simulink. Fig.3 shows the Simulink model of the test system. Phasor simulation is used to simulate the test system; so as to make it valid for intended purpose. The simulation time is 20 sec. The simulation is run in four different modes, as follows

- A. Without Fault and Without STATCOM
- B. Without Fault and With STATCOM
- C. With Fault and Without STATCOM
- D. With Fault and With STATCOM

In each case the pu voltage, active and reactive power at B25 bus are measured. When the STATCOM is connected to the system reactive power supplied by the STATCOM is also measured. For all the measurements, base power taken as 50 MVA and base voltage is 25 kV. Suitable sign convention is followed for measurement and subsequent analysis of active and reactive power at the bus.

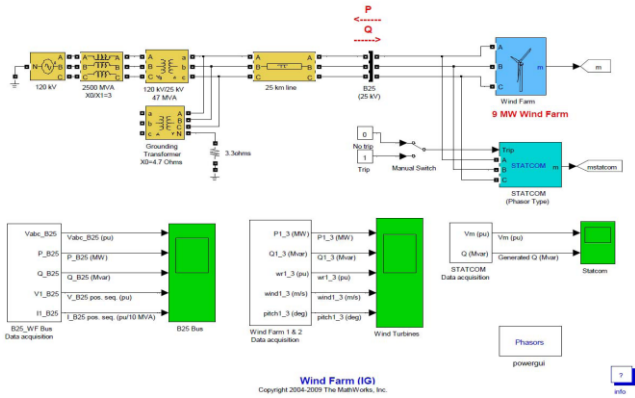

Fig. 3. Simulink Model (Test Model)

#### IV. SIMULATION RESULTS

##### A. Without Fault and Without STATCOM

In this mode the STATCOM was skipped while running the simulation. Only the grid system and the wind farm were kept in the model. The purpose of running the simulation in this mode is to ascertain that, the test system is a weak system. Thus, in this mode only voltages at B25 bus is measured.

Fig. 4 shows the voltages at B25 Bus. From this Fig. it seen that the voltage at B25 Bus is 0.94 pu. As these voltages are below 0.95 pu network taken for this study is really weak. Active and reactive power generated and absorbed by wind farm is also shown Fig.4.

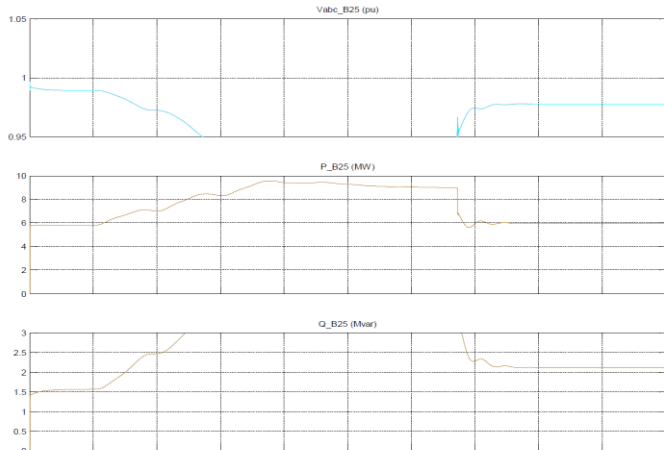

Fig. 4. Voltages, Active and Reactive Power at B25 Bus

##### B. Without Fault and With STATCOM

In this mode of simulation the wind farm with dynamic compensation by STATCOM is connected to the weak distribution network. The purpose of running simulation in this mode is to integrate 9 MW wind power in weak distribution network, with dynamic compensation of reactive power using the STATCOM. Fig.5 shows the voltage, active power supplied and reactive power required by wind turbine generators at B25 bus.

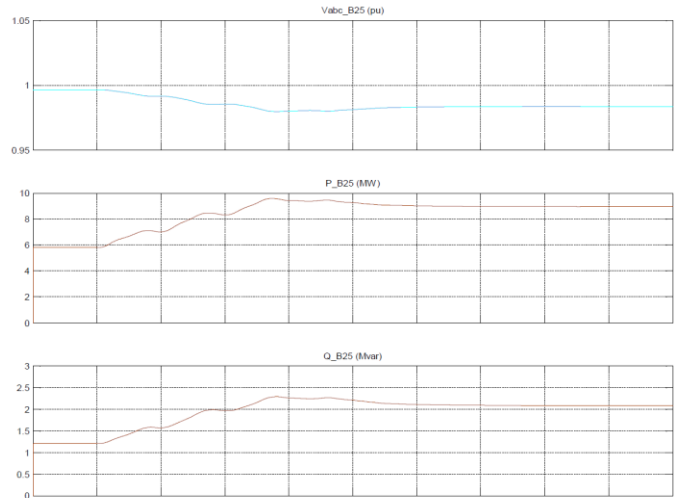

Fig. 5. Voltages, Active and Reactive Power at B25 Bus

From Fig.5 it seen that, in this case the wind turbine generators are not tripped. But they are supplying (3 x 3) MW power to the network.

From fig.6 it shows the reactive power supplied by the STATCOM.

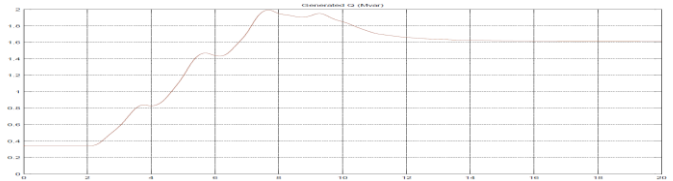

Fig.6. Reactive power supplied by STATCOM

It is seen that initially wind when the starting speed of turbine generators is low turbine generator draws less reactive power and it increases with speed. After 8 second later the reactive power demand is stabilized at (1.5 x 3) Mvar.

##### C. With Fault and Without STATCOM

This mode is same as above mode of simulation, but in this case at t=15 sec a temporary line to ground fault is applied at the low voltage terminals (575 V of "Wind Turbine 2").

The fault is initiated after 15 sec from starting of the simulation. The voltage, active power and reactive power at B25 bus during the fault is shown in fig.7.

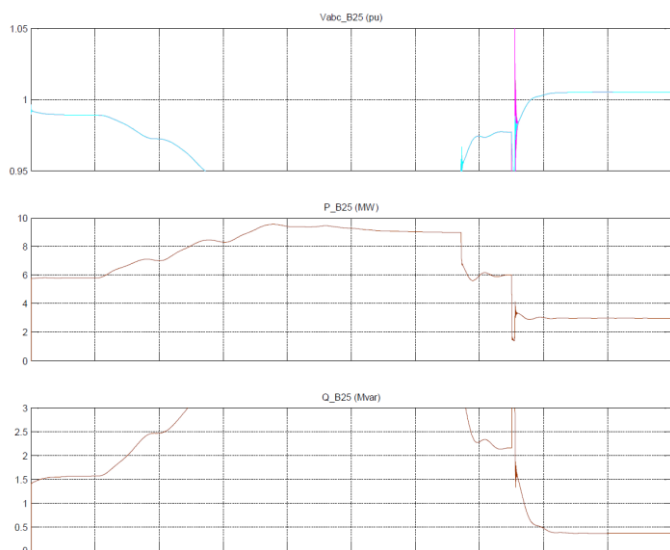

Fig. 7. Voltages, Active and Reactive Power at B25 Bus

It shows that voltage, active power supplied by wind turbine generators at B25 bus decreases and reactive power required during fault condition increases drastically by wind turbine generators connected to the distribution network.

#### D. With Fault and With STATCOM

This mode is same as above mode of simulation, but in this case a STATCOM is connected at B25 bus. At=15 sec a temporary line to ground fault is applied at the low voltage terminals (575 V) of "Wind Turbine 2" from starting of the simulation. The purpose of running simulation in this mode is to verify the dynamic reactive power compensation ability of STATCOM during the event of fault, while integrating wind power in a weak network.

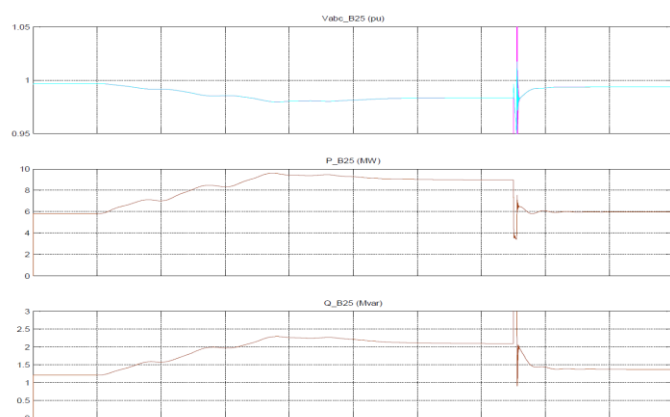

Fig. 8. Voltages, Active and Reactive Power at B25 Bus

Fig.8 shows voltage active power supplied by wind turbine generators to the network. From fig.8 it seen that, in this case the wind turbine generators are not tripped. But they are

continue to supply (3 x 3) MW power to the network. Fig.9 shows the voltage at B25 bus during and after fault. It is seen that voltage at B25 Bus improved since the STATCOM is supplying reactive power to the network even in the event of short duration fault at its point of interconnection. From Fig.9 it is seen that the voltage recovery after the fault is accelerated due to STATCOM and the system voltage restores before the initiation of protection systems. Thus the wind turbine generators do not trip even in the event of short duration fault.

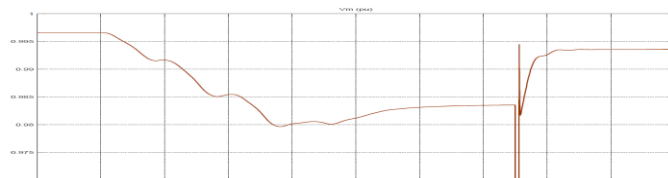

Fig. 9. Voltage at B25 Bus

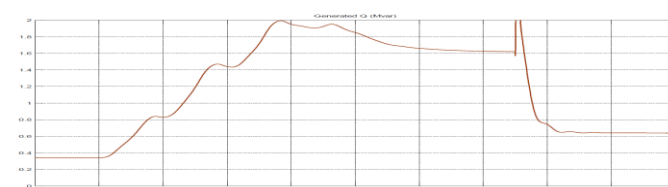

Fig. 10. Reactive power drawn by induction generators

#### V. CONCLUSION

This paper presented an evaluation study about the dynamic power compensation capability of STATCOM for the integration of wind power in a weak distribution network. The dynamic power compensation capability of STATCOM is also evaluated during an external phase to line to ground fault. The study reveals that, reactive power compensation by STATCOM makes it possible the integration of wind farm in a weak distribution network. STATCOM prevents large deviations of bus voltage due to reactive power drawn by wind turbine generators and also after fault the rapid recovery of voltage is resulted.

#### REFERENCES

- [1] H.T.Wu and Y. H. Liu, "Novel STATCOM Control Strategy for Wind Farm Reactive Power Compensation," IEEE Transactions on Energy Conversion 2011 IEEE.
- [2] Chong Han, Alex Q. Huang, Mesut E. Baran, "STATCOM Impact Study on the Integration of a Large Wind Farm into a Weak Loop Power System," IEEE Transactions on Energy Conversion, vol. 23, Issue 1, Mar. 2008, pp.226–233.
- [3] Zhen Xiang, Da Xie, Jinxia Gong, YanChi Zhang, "Dynamic Characteristics Analysis of STATCOM for Reactive Compensation in Wind Farm," Automation of Electric Power systems, vol. 32, Issue 9, May10,2008,pp.92–95.
- [5] S.Kahrobaee, S. Afshania, V. Salehipoor (University of Tehran), "Reasonable Reactive Power Control and Voltage Compensation for Wind Farms Using FACTS Devices", Nordic Wind Power Conference 22 – 23 May – 2006, ESPOO, Finland.
- [6] Ahmed Maria, Mauro Facca & John Diaz De Leon "IESO Philosophy On Reactive Power Compensation" North American WINDPOWER ® June 2007 issue.