

A study of a two stage maximum power point tracking control of a photovoltaic system under partially shaded insolation conditions

Kenji Kobayashi, Ichiro Takano^{*}, Yoshio Sawada

Kogakuin University, Tokyo 163-8677, Japan

Received 24 May 2005; accepted 21 September 2005

Available online 28 August 2006

Abstract

A photovoltaic (PV) array shows relatively low output power density, and has a greatly drooping current–voltage (I – V) characteristic. Therefore, maximum power point tracking (MPPT) control is used to maximize the output power of the PV array. Many papers have been reported in relation to MPPT. However, the current–power (I – P) curve sometimes shows multi-local maximum point mode under non-uniform insolation conditions. The operating point of the PV system tends to converge to a local maximum output point which is not the real maximal output point on the I – P curve. Some papers have been also reported, trying to avoid this difficulty. However, most of those control systems become rather complicated. Then, the two stage MPPT control method is proposed in this paper to realize a relatively simple control system which can track the real maximum power point even under non-uniform insolation conditions. The feasibility of this control concept is confirmed for steady insolation as well as for rapidly changing insolation by simulation study using software PSIM and LabVIEW. © 2006 Published by Elsevier B.V.

Keywords: Photovoltaic system; Two stage MPPT control; Non-uniform insolation

1. Introduction

Recently, the PV system attracted a great deal of attention with the trend of electric power deregulation and environmental preservation. However, the output density of the PV is low and the output of the PV depends highly on an insolation condition and a

^{*}Corresponding author.

E-mail address: ct97912@ns.kogakuin.ac.jp (I. Takano).

surface temperature of the PV array. Moreover, there are several local maximum power points in the $I-P$ characteristic under non-uniform insolation, whereas only one maximum power point in the $I-P$ characteristic of the PV under uniform insolation. Because of the above-mentioned PV characteristic, the maximum power point tracking (MPPT) control is performed to maximize the efficiency of the PV system. Many papers have been reported in relation to the MPPT control technique. Those papers are based on, for example, the mountain climbing method, the dV/dI method, fuzzy theory, genetic algorithm and so forth. The fuzzy theory and genetic algorithm can track the real maximum power point under partially shaded insolation distributions among these MPPT controls. However, most of those control processes are rather complicated, and sometimes the operating point is likely to converge on a local maximum power point which is not the true peak power point on the $I-P$ curve of the PV array.

Considering the above-mentioned situation, this paper describes a two stage MPPT control method which enables to track the real maximum power point on the $I-P$ curve swiftly with relatively simple control process even under non-uniform insolation conditions [1–3].

In order to operate this control system effectively, the concept of an equivalent resistance R_{pm} , proportional to the ratio of the open circuit voltage V_{oc} to the short circuit current I_{sc} , is introduced into this control process, where both V_{oc} and I_{sc} are monitored by online measurement. With the two stage MPPT method, the PV system will be controlled in such a way that the operating point of the PV system will move to the vicinity of the real peak power point on the load line R_{pm} at the first stage, and converge on the real peak power point finally at the second stage. It is confirmed by simulation study that this MPPT control system can track the real peak power point under non-uniform insolation conditions even when the insolation condition dramatically changes.

2. Characteristic of the PV array under non-uniform insolation conditions

$I-V$ and $I-P$ characteristics of the PV array show various modes under non-uniform insolation conditions, depending on the distribution of the shades. Eqs. (1), (2) and simulation software LabVIEW were used to analyze $I-V$ and $I-P$ characteristics of the PV array under non-uniform insolation conditions [4]:

$$I_2 = I_1 + I_{sc} \left[\frac{E_2 - E_1}{E_2} \right] + \alpha(T_2 - T_1), \quad (1)$$

$$V_2 = V_1 + \beta(T_2 - T_1) - R_s(I_2 - I_1) - KI_1(T_2 - T_1), \quad (2)$$

where α is the incremental value of I_{sc} when surface temperature changes 1°C ($\text{A}/^\circ\text{C}$) (under the standard condition), β is the incremental value of V_{oc} when surface temperature changes 1°C ($\text{V}/^\circ\text{C}$) (under the standard condition), R_s is the series resistance of a module (Ω) (under the standard condition), K is the curve correction factor ($\Omega/^\circ\text{C}$) (under the standard condition), I_{sc} is the short circuit current (under the standard condition), V_2 , I_2 , E_2 and T_2 are voltage, current, insolation intensity and surface temperature of a module under the standard condition, and V_1 , I_1 , E_1 and T_1 are measured values of voltage, current, insolation intensity and surface temperature of a module.

As shown in Table 1, the PV array studied in this paper consists of 930 sheets (modules), where 10 sheets are connected in series and 93 sheets connected in parallel. Each

Table 1
Major characteristics of the PV

Parameter	Module	Array
Maximum power	108.20 (W)	100.6 (kW)
Open circuit voltage (V)	43.00	430.0
Short circuit current (A)	3.35	311.6
Optimal operating voltage (V)	33.80	338.0
Optimal operating current (A)	3.20	297.6

Insolation intensity: 1000 W/m^2 , surface temperature: 25°C , connection: 10S–93P.

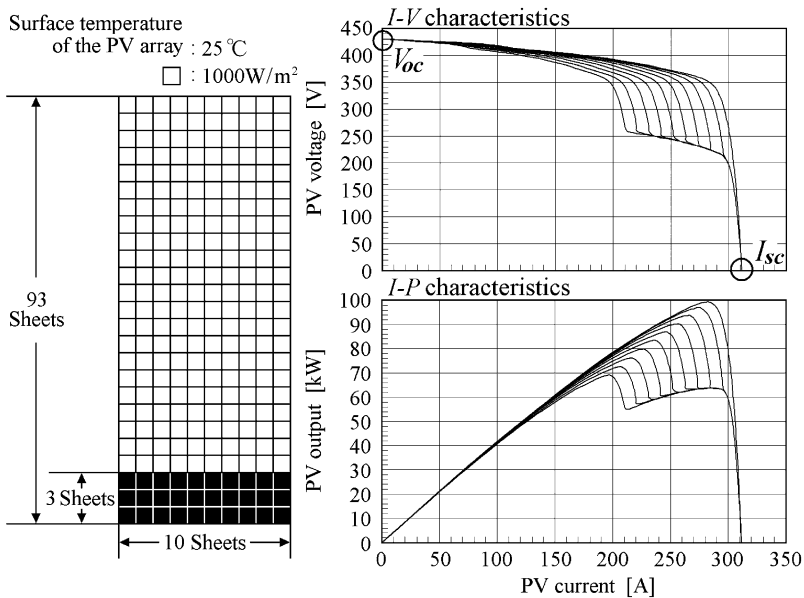

Fig. 1. *I-V* and *I-P* characteristics when 30 sheets are shaded.

sheet generates 108.2 W output under uniform insolation of 1000 W/m^2 and surface temperature of 25°C .

Figs. 1 and 2 show various patterns of the *I-V* and *I-P* curves, corresponding to various insolation intensities on the shade from 100 to 1000 W/m^2 with 100 W/m^2 step.

3. Concept of the two stage MPPT control

The PV system outline is shown in Fig. 3. The two stage MPPT control proposed in this paper will be performed by the inverter in cooperation with the boost chopper, and the system configuration and the control method will be explained in detail in Section 6. As mentioned above, there are various patterns of *I-V* and *I-P* curves under non-uniform insolation conditions, and the two patterns of *I-V/I-P* curves described in the following will be focused for the analysis in this paper as typical examples of those patterns. The first

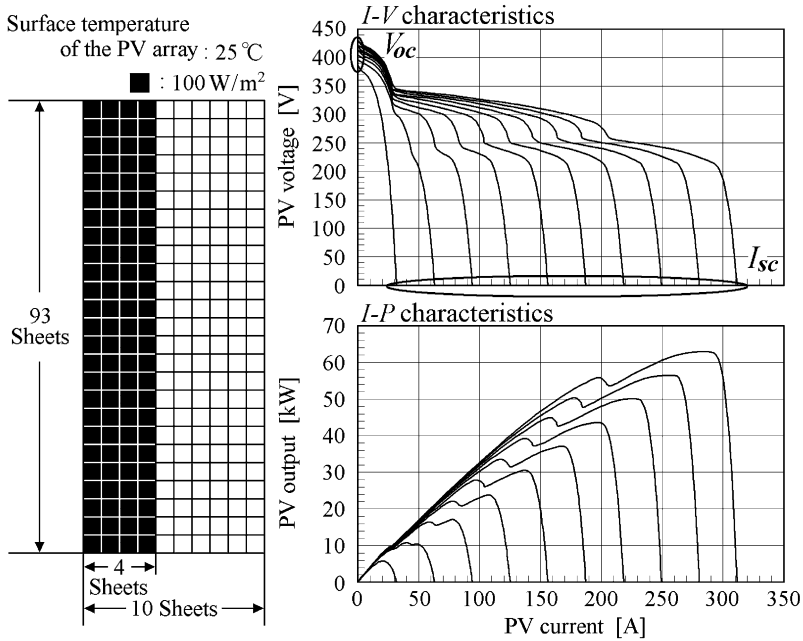

Fig. 2. $I-V$ and $I-P$ characteristics when 372 sheets are shaded.

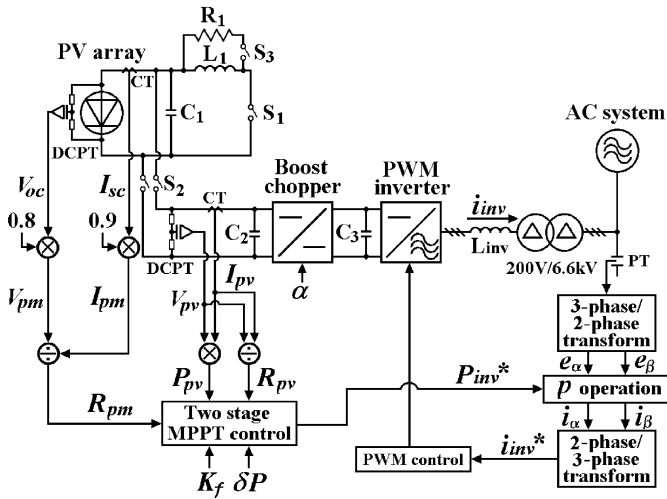

Fig. 3. Composition of the PV system.

pattern of the $I-V$ curve is that the real peak power point lies rather closer to the point of null current on the curve (see Fig. 1), and the second pattern is that the real peak power point lies closer to the point of null voltage in the curve (see Fig. 2). In the case of the first pattern of $I-V/I-P$ curves, it is not so difficult to track the real peak power point by the

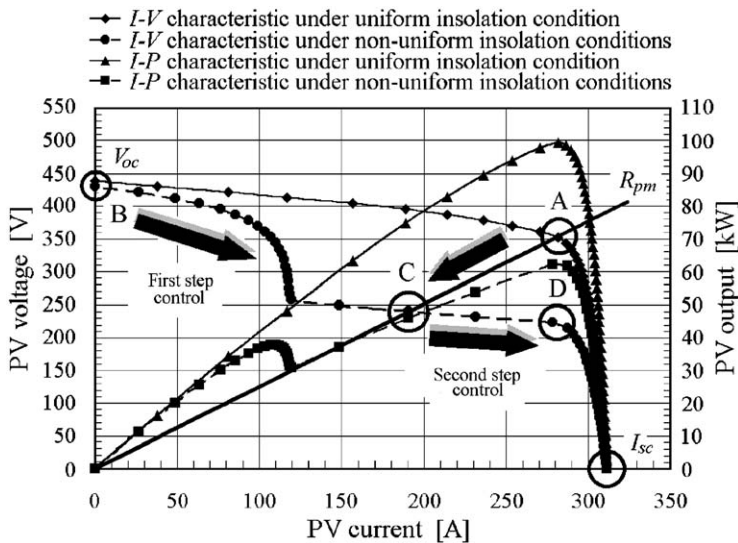

Fig. 4. $I-V$ and $I-P$ characteristics of the PV array under non-uniform insolation conditions and the two stage MPPT control process.

conventional mountain climbing method or the dV/dI method, whereas it is very likely for the PV system in the case of the second pattern to operate at a pseudo-peak power point which is not the real peak power point. Therefore, the authors propose the two stage MPPT control method which enables relatively simple control process even under rapidly changing non-uniform insolation. Fig. 5 shows the whole control process of this MPPT method, and Fig. 4 shows the movement of the operating points during the process of the proposed MPPT method. The numbers in Fig. 5 correspond to the same numbers in Fig. 4.

The first stage of the control process is to move the operating point to the vicinity of the real peak power point to avoid to converge to the local maximal power point, based on the following control algorithm. The control reference of the first step is an equivalent load line R_{pm} which is defined by Eq. (3) as the ratio of the optimal operating voltage V_{pm} to the optimal operating current I_{pm} under uniform insolation.

In other words, the operating point at the end of the first control is the point C in Fig. 4 which is the intersection of the $I-V$ curve and the load line

$$R_{pm} = \frac{V_{pm}}{I_{pm}}. \tag{3}$$

It is reported that V_{pm} and I_{pm} are approximately equal to 80% of the open circuit voltage V_{oc} and 90% of the short circuit current I_{sc} , respectively [5]. Then, if V_{oc} and I_{sc} are monitored by online measurement, the approximate value of R_{pm} can be obtained. After reaching the point C in Figs. 4 and 5, the control mode will be switched to the second stage mode. As the second stage control, the dV/dI control algorithm is used. Its basic concept can be explained as follows. Since the derivative of the output power P in terms of current I is equal to zero at the maximal point, the following can be obtained:

$$\frac{dP}{dI} = \frac{d}{dI}(V \cdot I) = 0,$$

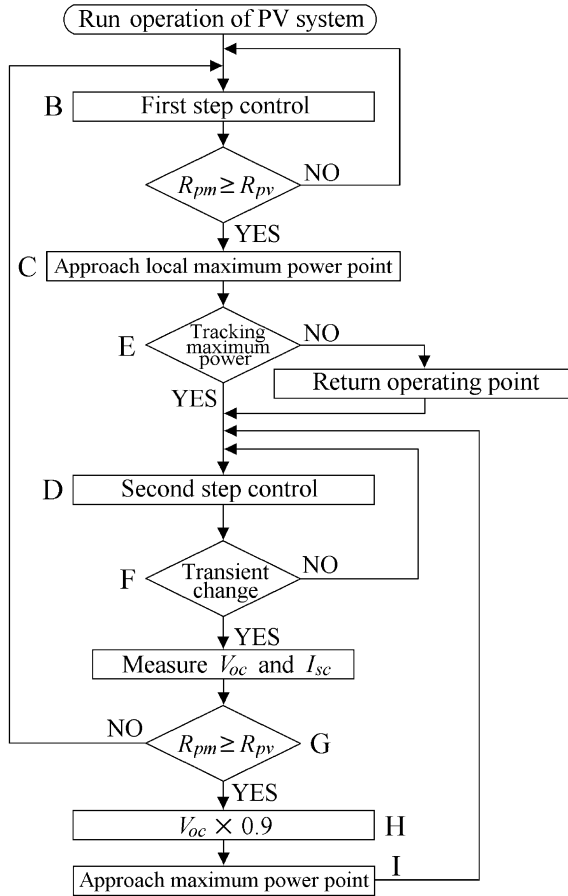

Fig. 5. Flow chart of the two stage MPPT control process.

$$\text{therefore } \frac{V}{I} = \frac{dV}{dI}. \tag{4}$$

Monitoring V/I and $-dV/dI$, both values are compared. If V/I is larger than $-dV/dI$, the current I will be increased by controlling the inverter (see Fig. 4). On the contrary, if V/I is smaller than $-dV/dI$, I will be decreased. In other words, the inverter will be controlled so as to minimize the difference between V/I and $-dV/dI$. Then, the operating point will converge to the point D in Fig. 4.

4. Discussion on various patterns of $I-V$ curves

The general concept of the two stage MPPT method was explained in Section 3. That is to say, the operating point of the PV array will be controlled to track the intersection of the $I-V$ curve and the equivalent load line of R_{pm} at the first stage, and then, shifted to real peak power point based on the dV/dI method at the second stage. It should be noted that the operating point on the $I-V$ curve under uniform insolation distribution lies on the load

line of R_{pm} . Considering the various patterns of an insolation distribution in the case of using the above-mentioned two stage MPPT control, a few questions will be raised about the following cases:

- The case when the operating point converges on a minimal power point on the $I-V$ curve at the end of the first stage, where dP/dI value is also equal to zero.
- The case when the operating point passes over the real maximum peak, and converges on somewhere in the vicinity of the pseudo-peak power point (a local maximal power point).

Fig. 6 shows transition of the equivalent resistance, corresponding to the constant shape of the shades and various insolation intensities of the shades on the PV array. In Fig. 6, the operating point can track the real maximum peak power point on the continuous lines, whereas the operating point cannot track the real peak power point on the broken line. The operating point at the end of the second stage may converge on the local maximal power point, the pseudo-peak power point, unless any effective countermeasures are taken. Considering comprehensive study on various patterns of $I-V/I-P$ curves, it has been found out that there is no real peak power point in the right side of the load line of R_{pm} on the $I-V$ plane in the cases of (a) and (b). Taking account of this phenomenon, the real peak power point can be tracked as follows. All maximal power points can be monitored during the first stage control, and associated data will be stored in the control circuit. And, if the operating point converges on somewhere in the vicinity of the pseudo-peak power point in the first stage, then the operating point will be shifted to the pseudo-peak power point in the second stage.

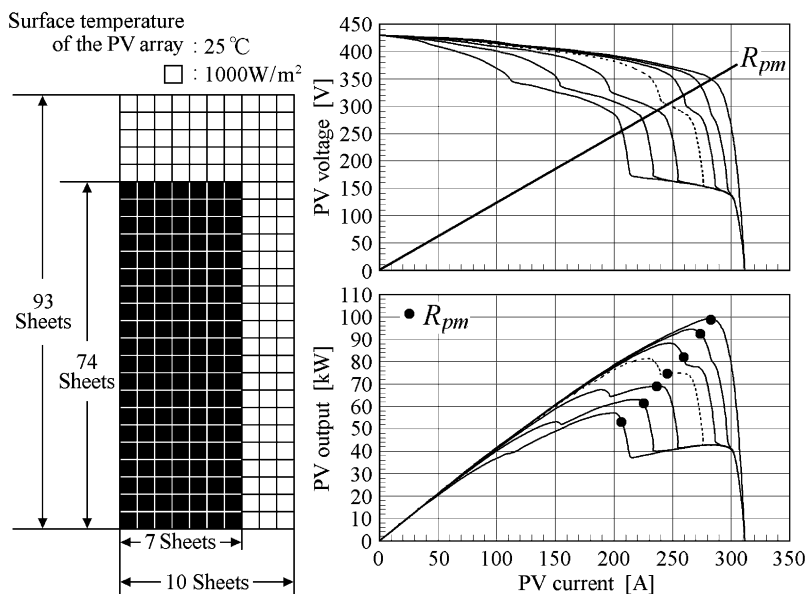

Fig. 6. Transition of the equivalent resistance.

Comparing the data of the maximal power point stored during the first stage control and that of the maximal power point at the end of the second stage, the real peak power point can be identified. Then, the operating point will be shifted to this real target.

Needless to say, if the operating point converges on somewhere in the vicinity of the real peak power point at the end of the first stage, the operating point will be shifted directly to the real target based on the dV/dI method during the second stage. The above-mentioned control process is summarized as the flow chart in Fig. 5.

5. Response for rapidly changing insolation during operation

When the insolation intensity and the patterns of shades over the PV array change to a great extent during the operation of the PV system, the operating point may be shifted from the real maximum peak power point to the local maximum power point. Therefore, the operating point should track the real peak power point, again. In the above-mentioned situation, the following two cases are supposed.

- (1) The case when the operating point shifts to the pseudo-peak power point of the V_{oc} side on the I – V plane on the basis of R_{pm} ($R_{pm} < R_{pv}$).
- (2) The case when the operating point shifts to the pseudo-peak power point of the I_{sc} side on the I – V plane on the basis of R_{pm} ($R_{pm} > R_{pv}$).

Case (1), that is to say, the case when the slope of R_{pv} is more than the slope of R_{pm} , can be regarded as the same conditions as the PV system operation start. Therefore, the normal two stage MPPT control is used in case (1). However, the normal two stage MPPT control cannot be used in case (2). The operating point may track the pseudo-peak power point for the case when the normal two stage MPPT control is used in case (2) and the above-mentioned cases (a) or (b). That is to say, the operating point may not pass over the real maximum peak power point, and a data P_{pm} of the real maximum peak power point may not be stored in the control circuit. Therefore, the following method controls the operating point of the PV array. The voltage output will be shifted temporarily to the point where the output voltage is 90% of V_{oc} , and the optimum power will be monitored during this process. Thereafter, the operating point will be shifted to the optimum power point, that is to say, the real peak power point, being controlled based on the dV/dI method.

The occurrence of the great change of insolation and shade condition will be judged by $dV/dI + V/I$ value and the output power until then. If a great change of the condition occurs, the reference values of V_{oc} and I_{sc} must be renewed by online measurement. These processes are also shown in the flow chart of Fig. 5.

6. System configuration and control method

Fig. 3 shows the PV system configuration studied in this paper. This system consists of the circuit which monitors V_{oc} and I_{sc} by online measurement, the booster type DC chopper as well as the full bridge–voltage source inverter controlled in PWM mode.

6.1. Online measurement of V_{oc} and I_{sc}

This circuit functions to monitor V_{oc} and I_{sc} by online measurement. When this circuit starts operating in the mode of online measurement of V_{oc} and I_{sc} , S_1 turns on whereas S_2 turns off (see Fig. 3). Then, the capacitance C_1 is short circuited through the inductance L_1 , and the terminal voltage of C_1 (PV array voltage) oscillates. During this oscillation process, the information of $I-V$ curves of the PV array can be obtained. The information about the optimum operating point could be obtained in principle. The whole process of this measurement can be finished within a very short period, for example 1 ms. The principle of this online measurement was originally reported by Tokyo Denki University and Gifu University; however, it was also reported that there are some experimental error inherent to this method due to the rapid transient phenomenon inside the solar cells [6,7].

Therefore, only the values of V_{oc} and I_{sc} are used for the MPPT control in this paper. The period T of the resonant oscillation is determined by

$$T = 2\pi\sqrt{L_1C_1}. \tag{5}$$

T is chosen as 2 ms in this paper on account of a restriction of the simulation. Therefore, the measurement time ($T/4$) is 500 μ s. During the online measurement of V_{oc} and I_{sc} , the PV array is separated from the chopper/inverter, and the voltage source to the chopper/inverter will be supplied by the capacitance C_2 .

6.2. Control of the boost chopper and the inverter

The boost chopper will be controlled so as to keep the input DC voltage of the inverter at constant value for stabilizing inverter operation, and the conduction ratio of the chopper α will be determined by

$$\alpha = 1 - \frac{V_{in}}{V_{out}} + K_{\alpha}(V_{out}^* - V_{out}), \tag{6}$$

where V_{in} is the input voltage of the chopper, V_{out} is the output voltage of the chopper, V_{out}^* is the desired value of the output voltage, K_{α} is the constant.

The inverter will be controlled based on pq theory [8]. During the second stage, the inverter will be controlled in accordance with the instruction shown in Table 3. As can

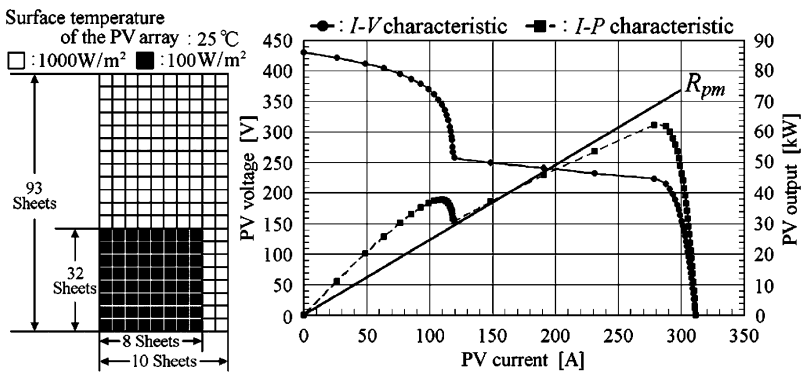

Fig. 7. Simulation conditions (case I).

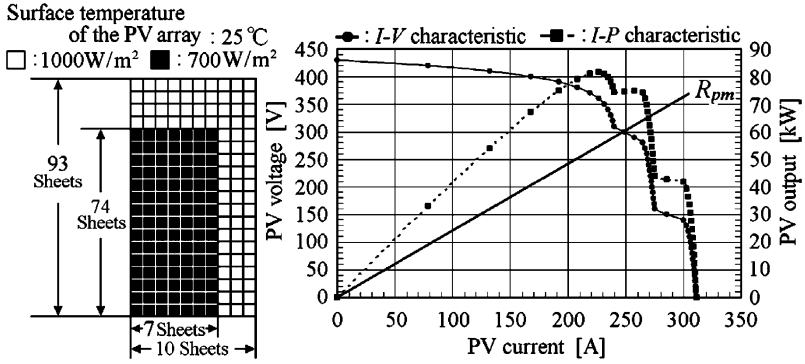

Fig. 8. Simulation conditions (case II).

Table 2
 Simulation conditions of the PV array

Parameter	Case I	Case II
Maximum power (kW)	62.6	81.2
Open circuit voltage (V)	430.0	430.0
Short circuit current (A)	311.5	311.5
Optimal operating voltage (V)	221.5	358.2
Optimal operating current (A)	282.4	226.6

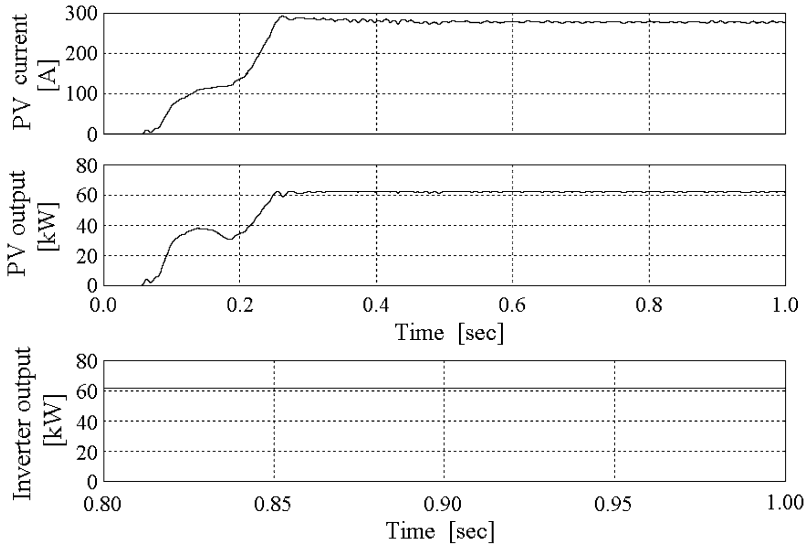

Fig. 9. Simulation results of case I.

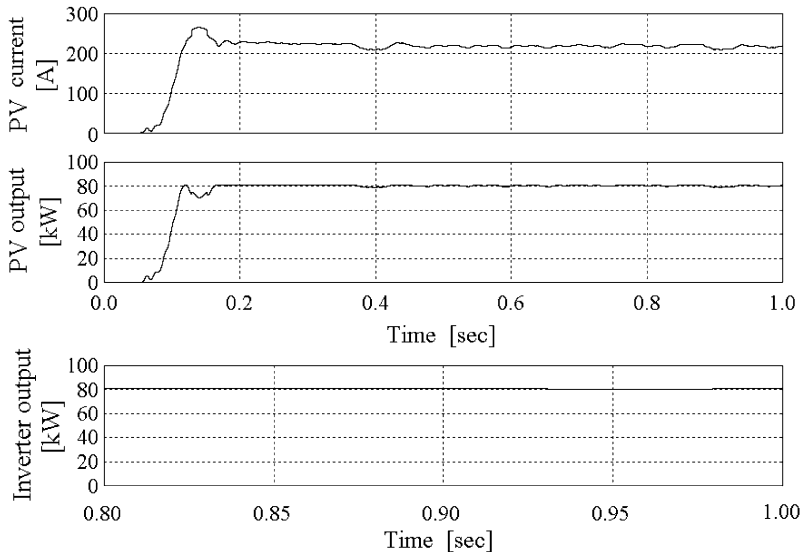

Fig. 10. Simulation results of case II.

been seen from Table 3, the instruction to control the inverter is given in such a way that the inverter can be operated in the slightly positive region of $dV/dI + V/I$ value in order to avoid unstable operation in the region of excessively negative value of dV/dI .

7. Simulation conditions and results

7.1. Simulation conditions

Simulations were performed for four patterns of non-uniform insolation conditions in relation to the PV array explained in Section 2 (see Table 1). Simulation conditions are explained as follows:

- (1) Case I: There are two local maximum power points on I – P curve, and the real peak power point lies on the right side of the load line R_{pm} (see Fig. 7).
- (2) Case II: The intersection of the load line R_{pm} and the I – V curve is located in the vicinity of a local maximal power point (see Fig. 8).
- (3) Case III: The pattern of I – V curve changes from that of case I to that of case II.
- (4) Case IV: The pattern of I – V curve changes from that of case II to that of case I. The simulation conditions mentioned above are summarized in Table 2.

7.2. Simulation results

Figs. 9–13 show the MPPT simulation results for the above-mentioned conditions. Figs. 9–12 show the waveforms of simulation results for cases I–IV. As can be seen from

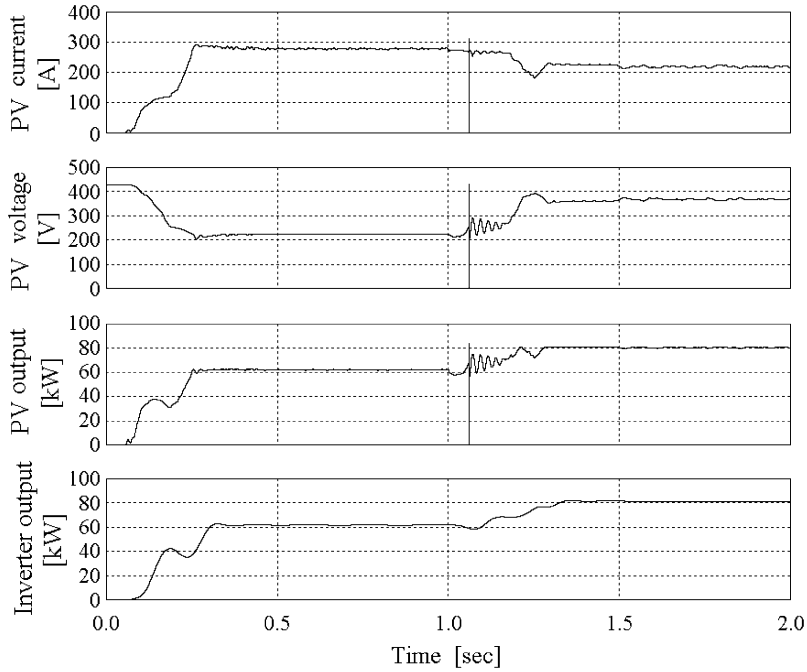

Fig. 11. Simulation results of case III.

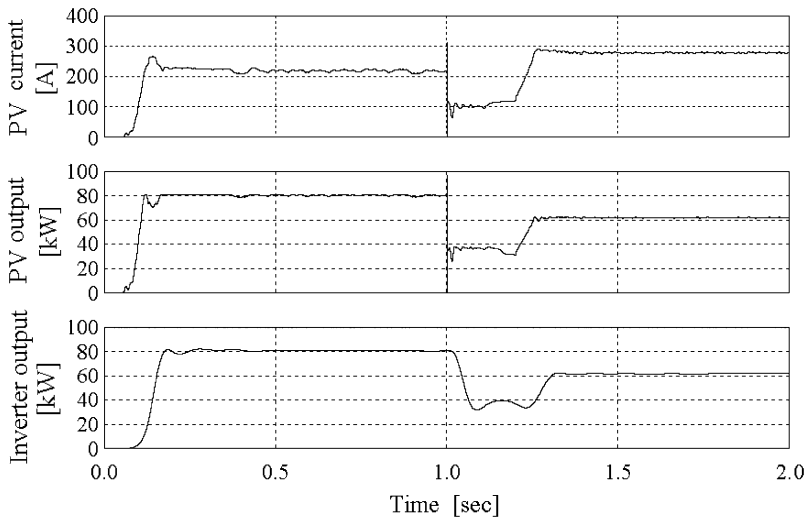

Fig. 12. Simulation results of case IV.

these figures, the two stage MPPT control proposed in this paper is successfully performed, and the response time varies from 0.2 to 0.3 s, depending upon the simulation conditions (Table 3). Fig. 13 shows the operating points as the result of the two stage MPPT control

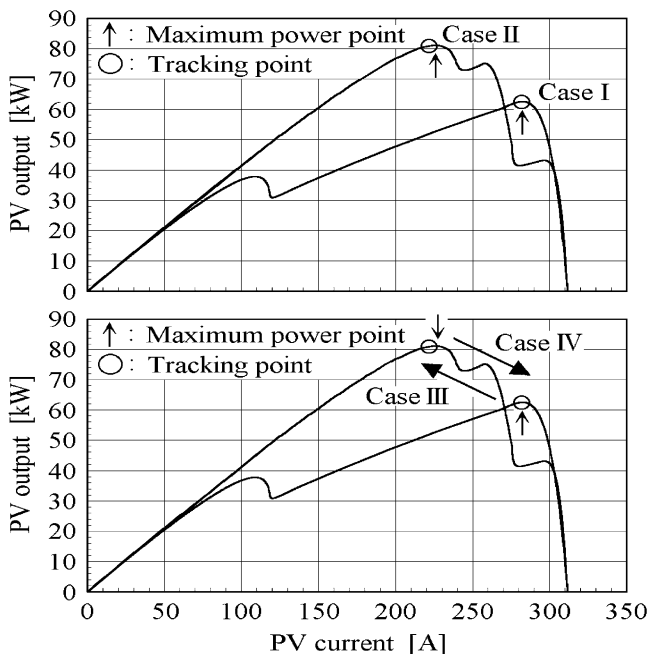

Fig. 13. Tracking point of each case and the two stage MPPT control.

Table 3
Control algorithm of the dV/dI method

Control	Equivalent resistance	$dV/dI + V/I$	For inverter reference
First-step control	$R_{pv} \geq R_{pm}$	–	$(P_{pv} + K_f)^*$
Second-step control	$R_{pv} < R_{pm}$	$0.5 < dV/dI + V/I$	$(P_{pv} + \delta P_+)^*$
		$0 \leq dV/dI + V/I \leq 0.5$	P_{pv}
		$0 > dV/dI + V/I$	$(P_{pv} - \delta P_-)^*$

simulations, and it is quite clear that these operating points agree well with the real peak power point of each condition.

8. Conclusion

The two stage MPPT control method combined with the instant online measurement of V_{oc} and I_{sc} was proposed in this paper. The feasibility of this control method was confirmed by the simulation study by PSIM software for various patterns of non-uniform insolation conditions. The simulation results show that the response time of this control system is within 0.3 s even under the great change of insolation pattern.

References

- [1] K. Kobayashi, Y. Horiuchi, I. Takano, Y. Sawada, A study on maximum power point tracking control of a photovoltaic system under non-uniform insolation conditions—analysis of control process by simulation, in: Proceedings of the 13th Annual Conference of Power and Energy Society, IEE Japan, vol. A, No. 196, 2002, pp. 605–606 (in Japanese).
- [2] K. Kobayashi, I. Takano, Y. Sawada, A study on a two stage maximum power point tracking control of a photovoltaic system under partially shaded insolation conditions, in: The Papers of Technical Meeting on SPC, IEE Japan SPC-03-11, 2003, pp. 63–70 (in Japanese).
- [3] K. Kobayashi, I. Takano, Y. Sawada, An experimental study on maximum power point tracking control of a photovoltaic system under non-uniform insolation conditions, in: Proceedings of the 2003 Japan Industry Applications Society Conference, IEE Japan, vol. 1-D, No. 90, 2003, pp. 443–444 (in Japanese).
- [4] H. Yamamoto, A. Iga, K. Ishihara, Y. Mita, H. Suzuki, Trans. IEE Japan 115-D (6) (1995) 702 (in Japanese).
- [5] Y. Takahashi, S. Akachi, I. Takano, Y. Sawada, A study on a simplified maximum power point tracking control using a photovoltaic (PV) module simulator, in: The Papers of Technical Meeting on SPC, IEE Japan, SPC-02-17, 2002, pp. 5–10 (in Japanese).
- [6] K. Ujiie, T. Kuroda, T. Izumi, T. Yokoyama, T. Haneyoshi, Study on dynamic and static characteristics of PV panel, in: Proceedings of the 2001 JIASC '01, IEE Japan, vol. 2, No. 222, 2001, pp. 945–948 (in Japanese).
- [7] D. Wang, H. Ishikawa, A new approach for instant location of photovoltaic maximum power point, in: Proceedings of the 2002 JIASC '02, IEE Japan, vol. 2, No. 200, 2002, pp. 887–888 (in Japanese).
- [8] H. Akagi, Y. Kanazawa, K. Fujita, A. Nabae, Trans. IEE Japan 58-B (60) (1983) 483 (in Japanese).