

# Approximate Feedback Linearization Around a Trajectory: Application to Trajectory Planning\*

John Hauser<sup>†</sup>

Andrzej Banaszuk<sup>‡</sup>

## Abstract

In this paper, we consider the approximate feedback linearization of a nonlinear system with one input in a neighborhood of a trajectory. We obtain a normal form for the dynamics in a neighborhood of a given trajectory. The normal form can be used to find a more aggressive trajectory in a vicinity of the original trajectory. The process can be repeated several times, yielding an iterative procedure for designing aggressive trajectories. An example is given to illustrate the approach.

**Keywords.** Nonlinear control, approximate linearization, trajectory planning.

## Introduction

For systems described by nonlinear models one is often interested in finding aggressive trajectories rather than merely stabilizing a constant operating point. Consider, for example, a helicopter performing a heavy lift operation to deliver water to a forest fire. In such a task, one is interested in connecting an initial and final point in the state space by an *aggressive* (e.g., fast) trajectory.

For nonlinear systems that satisfy the linear controllability and involutivity conditions necessary (and sufficient) for *exact* input-to-state linearization (see, e.g., [5] or [4]), the problem is easily solved. When, as is often the case, our system does not comply, we must resort to *approximations*. A number of approximate feedback linearization approaches have been studied include techniques for linearization about a point [6], linearization about an equilibrium manifold [3, 7], and linearization about a region in a least squares sense [2].

In [3], the problem of finding trajectories connecting two equilibrium points was considered. It has been shown that this can be accomplished by finding a coordinate system in a neighborhood of the equilibrium manifold and designing a tracking control law for a trajectory of a linear system approximating given system about the equilibrium manifold. It has been shown that if the desired trajectory of the system stays  $\epsilon$ -close to

the equilibrium manifold then there is an actual trajectory of the real system that is  $\epsilon^2$ -close to the desired one. This approach allows one to connect connecting two equilibrium points by trajectories that stay close to the equilibrium manifold. As a consequence of being close to the equilibrium manifold, these trajectories are necessarily *slow*.

In this paper we show how one can connect two equilibrium points by *aggressive* trajectories. Such trajectories do not remain close to the equilibrium manifold.

The approach taken in this paper is to find an input-to-state linearizable nonlinear system that *approximates* the given nonlinear system in a neighborhood of a given trajectory. We obtain a normal form for the dynamics in a neighborhood of a given trajectory. Since we use a homotopy operator approach (cf. [1]), our approach is *constructive* requiring only the solution of ODEs. The normal form can be used to find a more aggressive trajectory in a vicinity of the original trajectory. The process can be repeated several times, yielding an iterative procedure for designing aggressive trajectories. An example is given to illustrate the approach.

## 1. Approximate Feedback Linearization in a Neighborhood of a Trajectory

The main object of study in this paper is the *affine nonlinear control system*:

$$(f, g) : \dot{x} = f(x) + g(x)u$$

Here  $f$  and  $g$  are  $C^\infty$ .

Many physical systems are designed to be controlled over a certain region. We assume that we will only operate the system in the region  $\mathcal{M}$  where the system is *linearly controllable*, i.e.,

$$\dim \text{span} \{g, ad_f g, \dots, ad_f^{n-1} g\} = n, \forall x \in \mathcal{M}, \quad (1)$$

(where the  $ad_f^i g$  are iterated Lie brackets of  $f$  and  $g$ ).

We define the *characteristic distribution* for  $(f, g)$

$$\mathcal{D} := \text{span} \{g, ad_f g, \dots, ad_f^{n-2} g\}$$

(it is an  $(n-1)$ -dimensional smooth distribution by assumption of linear controllability (1)). We shall call

\*Research supported in part by AFOSR under grant number F49620-96-1-0141 and by NSF under grant number PYI ECS-9157835.

<sup>†</sup>Electrical and Computer Engineering, University of Colorado, Boulder, CO 80309-0425, hauser@colorado.edu.

<sup>‡</sup>United Technologies Research Center, 411 Silver Lane, MS 129-15, East Hartford, CT 06108, banasza@utrc.utc.com.

any nowhere vanishing one-form  $\omega$  annihilating  $\mathcal{D}$  a *characteristic one-form* of the system  $(f, g)$ . All the characteristic one-forms of  $(f, g)$  can be represented as multiples of some fixed characteristic one-form  $\omega_0$  by a smooth nowhere vanishing function (zero-form)  $\beta$ . Suppose that there is a nonvanishing  $\beta$  such that  $\beta\omega_0$  is exact, i.e.,  $\beta\omega_0 = d\alpha$  for some smooth function  $\alpha$  ( $d$  denotes the exterior derivative). Then  $\omega_0$  is called *integrable* and  $\beta$  is called an *integrating factor* for  $\omega_0$ .

Recall that a *homotopy operator* is an operator  $H$  mapping  $k$ -forms to  $(k-1)$ -forms and satisfying the *homotopy identity*

$$d(H\zeta) + Hd\zeta = \zeta.$$

Let  $\eta$  be an integral curve of  $f$ . We define a homotopy operator  $H$  in a neighborhood of  $\eta$ . The value of  $H$  acting on a form  $\zeta$  at a point  $x$  will be defined by integrating the form  $\zeta$  along a path from a given point  $x^0$  on  $\eta$  (typically,  $x^0$  will be the initial point of  $\eta$ ) to  $x$  obtained as follows. Let  $\Pi x$  will be the projection of  $x$  onto  $\eta$  (w.r.t. a fixed Riemannian metric) so that  $\Pi x$  is the point on  $\eta$  closest to  $x$ . We shall denote the geodesic distance between points  $x$  and  $y$  as  $|x-y|$ . We assume that  $x$  is sufficiently close to  $\eta$  so that the projection is well defined. The path of integration from  $x^0$  to  $x$  will be obtained by first connecting  $x^0$  with  $\Pi x$  along  $\eta$  and then by connecting  $\Pi x$  with  $x$  along the projection geodesic. It is clear that  $H$  is a linear mapping (over the reals).

Using a special set of coordinates around  $\eta$ , we can give a simple formula for action of the homotopy operator  $H$  on a one-form  $\zeta$ . Suppose that  $x = (x_1, \dots, x_n)$  are coordinates such that  $f = \frac{\partial}{\partial x_1}$  on  $\eta$  and such that the projection onto  $\eta$  is given by  $(x_1, x_2, \dots, x_n) \mapsto (x_1, 0, \dots, 0) \in \eta$ . For convenience, we write  $x = \sum_{j=1}^n x_j e_j$  where  $e_1 = (1, 0, \dots, 0)$ , etc. Taking the distinguished point  $x^0$  to be the origin, we see that  $H\zeta$  with  $\zeta(x) = \sum_{i=1}^n \zeta_i(x) dx_i$  is given by

$$(H\zeta)(x) = \int_0^{x_1} \zeta_1(se_1) ds + \sum_{i=2}^n \int_0^1 \lambda x_i \zeta_i(x_1 e_1 + \lambda \sum_{j=2}^n x_j e_j) d\lambda. \quad (2)$$

From this expression it is easy to see that

**Lemma 1.1** *On  $\eta$*

$$d(H\zeta) = \zeta$$

for any one-form  $\zeta$  defined on a neighborhood of  $\eta$ .

*Proof:* Differentiating (2) we see that

$$\frac{\partial h}{\partial x_k}(x) = \zeta_k(x), \quad x \in \eta$$

where  $h(x) = (H\zeta)(x)$ . The result follows since all expressions are coordinate independent.  $\square$

Let  $\omega$  be any characteristic one-form of  $(f, g)$  and define  $\omega_i := L_f^{i-1}\omega$  and

$$\begin{aligned} z_1 &:= H\omega_1 = H\omega, \\ z_2 &:= H\omega_2 = HL_f\omega, \\ &\vdots \\ z_n &:= H\omega_n = HL_f^{n-1}\omega. \end{aligned} \quad (3)$$

It is easy to see that the mapping  $\Phi : x \mapsto z$  provides a valid coordinate change in a neighborhood of  $\eta$  when the system is linearly controllable:

**Proposition 1.2** *Suppose that  $(f, g)$  is linearly controllable. Then, the differentials  $dz_i$ ,  $i = 1, \dots, n$ , are linearly independent on  $\eta$ .*

*Proof:* By Lemma 1.1,  $dz_i = L_f^{i-1}\omega$  on  $\eta$ . Linear independence follows from linear controllability.  $\square$

In  $z$  coordinates, the system  $(f, g)$  has the form

$$\begin{aligned} \dot{z}_1 &= z_2 && + \psi_1(x) + \theta_1(x)u \\ &\vdots && \\ \dot{z}_{n-1} &= z_n && + \psi_{n-1}(x) + \theta_{n-1}(x)u \\ \dot{z}_n &= p(x) + r(x)u && + \psi_n(x) + \theta_n(x)u \end{aligned} \quad (4)$$

Recall that a function  $x \mapsto \lambda(x)$  is higher order at  $x^0$  if  $\lambda$  together with all its first derivatives vanish at  $x^0$ . Analogously, given a smooth manifold  $\mathcal{N}$ , we say that a function  $\lambda$  is *higher order on  $\mathcal{N}$*  if  $\lambda$  and all its first derivatives vanish on  $\mathcal{N}$ . Similarly,  $\lambda$  is *order  $\rho$  on  $\mathcal{N}$*  if  $\lambda$  and all derivatives up to order  $\rho-1$  vanish on  $\mathcal{N}$ . For example, the function  $x \mapsto x_1 x_2^2$  is higher order on  $\mathcal{N} = \{x \in \mathbb{R}^2 : x_2 = 0\}$ .

**Proposition 1.3** *The functions  $\psi_i$ ,  $i = 1, \dots, n$ , are higher order on  $\eta$  and the functions  $\theta_i$ ,  $i = 1, \dots, n$ , are at least first order on  $\eta$ .*

*Proof:* Using the homotopy identity, one obtains  $\omega_i = L_f^{i-1}\omega = dz_i + \epsilon_i$ ,  $i = 1, \dots, n$ , where  $\epsilon_i := Hd\omega_i$ . Since  $\epsilon_i = 0$  on  $\eta$  (Lemma 1.1), we see that  $L_f\epsilon_i$  also vanishes on  $\eta$  since  $f$  is tangent to  $\eta$ . Therefore  $|\epsilon_i|$  and  $|L_f\epsilon_i|$  grow at most linearly as functions of  $|x - \Pi x|$ .

Now, for  $i = 1, \dots, n$ , we have  $\psi_i = L_f z_i - z_{i+1} = L_f z_i - H\omega_{i+1} = L_f z_i - HL_f\omega_i = L_f z_i - HL_f(dz_i + \epsilon_i) = L_f z_i - HdL_f z_i - HL_f\epsilon_i = L_f z_i - L_f z_i - HL_f\epsilon_i = -HL_f\epsilon_i$ . Since  $|L_f\epsilon_i|$  grows at most linearly as a function of  $|x - \Pi x|$ , we see that  $|\psi_i| = |-HL_f\epsilon_i|$  grows at most quadratically as a function of  $|x - \Pi x|$ .

Also, since  $\theta_i = L_g z_i = i_g dz_i = i_g(\omega_i - \epsilon_i) = -i_g \epsilon_i$  for  $i = 1, \dots, n$ , we see that  $|\theta_i|$  grows at most linearly as a function of  $|x - \Pi x|$ . Here  $i_g \zeta$  is the contraction of a vector field  $g$  with a form  $\zeta$ .  $\square$

When  $(f, g)$  is feedback linearizable, one can choose  $\omega$  to be integrable. In this case, the error one-forms  $\epsilon_i$  vanish so that the  $\psi_i$  and  $\theta_i$  terms will be zero.

If the system is close to being linearizable, one can find a characteristic one-form  $\omega$  that is close to being integrable together with some derivatives (for instance, by constructing higher order least-squares integrating factors). In this case some number of derivatives of the error one-forms  $\epsilon_i$  will be small near  $\eta$  so that the error terms  $\psi_i$  and  $\theta_i$  will also be small near  $\eta$ .

Since the functions  $\psi_i$ , are higher order on  $\eta$  and the functions  $\theta_i$ , are first order on  $\eta$ , the system

$$\begin{aligned} \dot{z}_1 &= z_2 \\ &\vdots \\ \dot{z}_{n-1} &= z_n \\ \dot{z}_n &= p(x) + r(x)u \end{aligned} \quad (5)$$

approximates  $(f, g)$  to first order on  $\eta$ . Of course, when  $(f, g)$  is close to linearizable, the approximation error (on a neighborhood of  $\eta$ ) will be small. Furthermore, the approximate system (5) is differentially flat with flat output  $y = z_1$  and input to state linearizable (use  $u = (v - p(x))/r(x)$ ).

## 2. Stability and Continuity Properties

We can easily stabilize the trajectory  $\eta$  of the original system using this approximation. First, let  $\xi_d(t)$ ,  $t \geq 0$ , be a  $C^1$  desired trajectory satisfying  $\xi_{di}(t) = y_d^{(i)}(t)$ ,  $t \geq 0$ ,  $i = 1, \dots, n$ , for some  $C^n$  desired (output) function  $y_d(\cdot)$ . Provided that  $r(\Phi^{-1}(\xi_d(t))) \neq 0$ ,  $t \geq 0$ , so that linear controllability is never lost, application of the control law

$$u(x, t) = \frac{1}{r(x)} \left[ -p(x) + \dot{\xi}_{dn}(t) + \sum_{i=1}^n a_i (\xi_{di}(t) - z_i(x)) \right] \quad (6)$$

to the approximate system (5) will provide stable tracking of the desired trajectory  $\xi_d(\cdot)$ . (In (6), we require the coefficients  $a_i$  to be such that  $s^n + a_n s^{n-1} + \dots + a_2 s + a_1$  is a Hurwitz polynomial.) Indeed, the error  $e := z - \xi_d$  is governed by the linear dynamics  $\dot{e} = Ae$  where  $A$  is the appropriate companion matrix.

Now, suppose that the control (6) is applied to the original system (4). In this case, the error dynamics becomes

$$\dot{e} = Ae + w(e, t)$$

where the perturbation term is given by  $w = \psi + \theta u$ . For general  $\xi_d(\cdot)$  we cannot say much—the system may even cease to be well defined in finite time. However, if the desired trajectory lives in  $\eta$ , e.g.,  $\xi_d(t) = \xi_d^0(t) := \Phi(\phi_t(x^0))$ , then the error  $w(e, t)$  will be higher order in  $e$ . Here  $\phi_t(x)$  denotes the flow of the system at time  $t$  starting from the initial condition  $x$ . Under reasonable conditions that provide uniformity of the error with respect to time (e.g., a bounded desired trajectory), we see that  $\xi_d^0(\cdot)$  would be an exponentially stable trajectory of the closed loop system (4), (6). We will see that this stability property actually allows us to conclude quite a bit about the behavior of the system for trajectories near  $\eta$ .

Suppose that  $(f, g)$  and  $x^0$  are such that the closed loop system (4), (6) provides stable tracking of the desired trajectory  $\xi_d^0(\cdot)$ . In this case, the closed loop system defines a mapping

$$\mathcal{P} : \{(\xi_d(t), \dot{\xi}_{dn}(t)), t \geq 0\} \mapsto \{(z(t), \dot{z}_n(t)), t \geq 0\}$$

for desired trajectories  $\xi_d$  close to  $\xi_d^0$ . For simplicity, we shall write  $z(\cdot) = \mathcal{P}(\xi_d(\cdot))$ .

The mapping  $\mathcal{P}$  possesses a number of interesting properties. First, note that  $\xi_d^0(\cdot)$  is a fixed point of the nonlinear mapping  $\mathcal{P}$ . Second, note that  $\mathcal{P}$  projects approximate trajectories of  $(f, g)$  onto actual (or exact) trajectories of  $(f, g)$ .

To make these ideas precise, we will study some continuity properties of a truncated version of the mapping given by

$$\mathcal{P}_T : \{(\xi_d(t), \dot{\xi}_{dn}(t)), t \in [0, T]\} \mapsto \{(z(t), \dot{z}_n(t)), t \in [0, T]\}.$$

We measure the distance between  $C^1$  trajectories  $\xi(\cdot)$  and  $\zeta(\cdot)$  according to

$$\|\xi(\cdot) - \zeta(\cdot)\| := \max_{t \in [0, T]} |\xi(t) - \zeta(t)|_n + \left| \dot{\xi}_n(t) - \dot{\zeta}_n(t) \right|$$

where  $|\cdot|_n$  is the Euclidean norm on  $\mathbb{R}^n$ .

**Theorem 2.1** *Let  $T > 0$  be given and suppose that  $r(\phi_t(x^0)) \neq 0$  for  $t \in [0, T]$ . There exists positive constants  $k$  and  $\epsilon_0$  such that*

$$\|\mathcal{P}_T(\xi_d(\cdot)) - \xi_d(\cdot)\| \leq k \|\xi_d(\cdot) - \xi_d^0(\cdot)\|^2$$

for all  $\xi_d(\cdot)$  such that  $\|\xi_d(\cdot) - \xi_d^0(\cdot)\| < \epsilon_0$ .

*Proof:* Fix  $T > 0$  and let  $\epsilon_0 > 0$  be such that  $r(\Phi^{-1}(z))$  is nonzero and the projection  $z \mapsto \Pi z$  is well defined for all  $z$  such that  $|z - \xi_d^0(t)| < 2\epsilon_0$  for some  $t \in [0, T]$ . Let  $\epsilon \in (0, \epsilon_0)$  and suppose that  $\|\xi_d(\cdot) - \xi_d^0(\cdot)\| < \epsilon$ . Then, defining  $e(t) := z(t) - \xi_d(t)$ , we see that, for  $|e(t)| < \epsilon$ ,

$$\begin{aligned} |z(t) - \Pi z(t)| &\leq |z(t) - \Pi \xi_d(t)| \\ &\leq |z(t) - \xi_d(t)| + |\xi_d(t) - \Pi \xi_d(t)| \\ &\leq |e(t)| + \epsilon. \end{aligned}$$

Now, consider the perturbation term  $w(e, t) = \psi(x) + \theta(x)u(x, t)$ . We claim that there is a positive  $k_1$  such that  $|w(e, t)| \leq k_1(|e(t)| + \epsilon)^2$  for all  $e \in (0, \epsilon_0)$ . Since  $\theta$  and  $\psi$  are first and second order on  $\eta$ , respectively, we need only check that  $u$  also exhibits a suitable linear growth property. Define  $a_0 := \max_i a_i$  (where the  $a_i$  are the feedback gains given in (6)),

$$r_0 := \max_{t \in [0, T], |e| \leq 2\epsilon_0} \left| \frac{1}{r(x)} \right|_{x = \Phi^{-1}(\xi_d^0(t) + e)},$$

$$p_0 := \max_{t \in [0, T], |e| \leq 2\epsilon_0} |p(\Phi^{-1}(\xi_d^0(t) + e)) - p(\Phi^{-1}(\xi_d^0(t)))|,$$

and note that  $p(\Phi^{-1}(\xi_d^0(t))) = \dot{\xi}_{dn}^0(t)$ ,  $t \geq 0$ . We have, for  $|e(t)| < \epsilon_0$ ,

$$\begin{aligned} |u(x(t), t)| &\leq r_0(|p(x(t)) - \dot{\xi}_{dn}(t)| + a_0|e(t)|) \\ &\leq r_0(|p(x(t)) - p(\Phi^{-1}(\xi_d^0(t)))| \\ &\quad + |\dot{\xi}_{dn}^0(t) - \dot{\xi}_{dn}(t)| + a_0|e(t)|) \\ &\leq r_0((p_0 + 1)\epsilon + a_0|e(t)|) \end{aligned}$$

The claim follows easily.

Consider the Lyapunov function  $V(e) = e^T P e$  where  $P > 0$  satisfies  $A^T P + P A + I = 0$ . Calculating, we have

$$\begin{aligned} \dot{V}(e(t), t) &= -|e(t)|^2 \\ &\quad + 2e(t)^T P(\psi(x(t)) + \theta(x(t))u(x(t), t)) \\ &\leq -|e(t)|^2 + k_2|e(t)|(\epsilon + |e(t)|)^2 \\ &\leq -(1 - 2k_2\epsilon - k_2|e(t)|)|e(t)|^2 + k_2\epsilon^2|e(t)| \\ &\leq -(1 - 3k_2\epsilon_0)|e(t)|^2 + k_2\epsilon^2|e(t)| \end{aligned}$$

whenever  $|e(t)| < \epsilon_0$  where  $k_2 := 2k_1|P|$  and  $|P| = \lambda_{\max}(P)$ . Reducing  $\epsilon_0$ , if necessary, so that  $3k_2\epsilon_0 < 1/2$ , we obtain

$$\begin{aligned} \dot{V}(e(t), t) &\leq -\frac{1}{2}|e(t)|^2 + k_2\epsilon^2|e(t)| \\ &\leq -\frac{1}{4}|e(t)|^2 - \left(\frac{1}{2}|e(t)| - k_2\epsilon^2\right)^2 + k_2^2\epsilon^4 \\ &\leq -\frac{1}{4}|e(t)|^2 + k_2^2\epsilon^4. \end{aligned}$$

We see that  $\dot{V} < 0$  on the set

$$2k_2\epsilon^2 < |e(t)| < \epsilon_0$$

which is nonempty since  $2k_2\epsilon^2 < \epsilon_0/2 < \epsilon_0$ . Furthermore, since  $e(0) = 0$  ( $\Rightarrow V(e(0)) = 0$ ) and

$$\dot{V}(e(t), t) \leq -\frac{1}{4|P|}V(e(t)) + k_2^2\epsilon^4,$$

we see that  $V(e(t)) \leq 4|P|k_2^2\epsilon^4$  so that

$$|e(t)| \leq k\epsilon^2, \quad t \geq 0,$$

where  $k := 2k_2\sqrt{|P|/\lambda_{\min}(P)} = 4k_1\sqrt{|P|^3/\lambda_{\min}(P)}$ .  $\square$

This result says that we obtain  $\epsilon^2$  tracking of trajectories that are  $\epsilon$  close to the manifold (i.e., trajectory) about which the approximation is made. Note that the guarantee is given over the *finite* time interval  $[0, T]$ . Results on an infinite time interval (i.e., stability results) can be easily derived using a similar proof when appropriate technical conditions (e.g., boundedness and uniformity) are postulated.

In the above proof we see that the Lyapunov distance  $\sqrt{V(e)}$  decreases whenever

$$4k_1|P|\epsilon^2 < |e| < \epsilon_0 < \frac{1}{12k_1|P|}.$$

These bounds have a simple interpretation. The constant  $k_1$  provides a measure of the effect of the *nonlinear* terms in a neighborhood of  $\eta$ . The upper bound

says that the nonlinear (and time varying) terms  $\psi(x)$  and  $\theta(x)u(x, t)$  may well dominate the stabilizing linear term  $Ae$  as we get further away from  $\eta$ . The lower bound (a sufficient condition) is an indication that the desired trajectory  $\xi_d(\cdot)$  may not be a realizable trajectory when  $\psi$  and  $\theta$  are nonzero. When the system is close to being linearizable, an approximation resulting in small  $k_1$  should be possible indicating small tracking errors and a large region of attraction.

### 3. Application to Trajectory Planning

Suppose we are interested in finding aggressive trajectories between the equilibrium points, say  $x_0$  and  $x_1$ . Given a trajectory between these points, we can find a more aggressive one in the following manner.

Let  $x^i(t)$ ,  $u^i(t)$ ,  $t \in [0, T]$ , denote the given state and control trajectories and let  $\eta^i$  denote the manifold traced out by  $x^i$ . We convert the time function  $u^i(t)$  into a state feedback  $k^i(x)$  defined on a neighborhood of  $\eta$  according to

$$k^i(x) = u^i(\tau(\Pi x))$$

where  $\Pi$  projects to the nearest point on  $\eta$  and  $\tau$  selects the time index so that  $x^i(\tau(\Pi x)) = \Pi x$ . In other words,  $k^i$  sets the input to  $u^i(t)$  for all  $x$  belonging to the plane normal to  $\eta^i$  at  $x^i(t)$ . Now, define

$$f^i(x) = f(x) + g(x)k^i(x)$$

for  $x$  in a neighborhood of  $\eta^i$  and note that  $\eta^i$  is an integral manifold of  $f^i$ .

Now, let  $H^i$  be the homotopy operator obtained by integration along  $\eta^i$  (and the projection geodesic) and define locally linearizing coordinates

$$z_k^i = H^i L_{j_i}^{k-1} \omega$$

for  $k = 1, \dots, n$ . Using these coordinates, we construct the stabilizing feedback law and an associated projection operator  $\mathcal{P}^i$  with fixed point trajectory  $\xi_d^i(t) = z^i(x^i(t))$ ,  $t \in [0, T]$ . As shown above, the closed loop system provides stable approximate tracking of trajectories near  $\xi_d^i(\cdot)$ . Let  $y_i(t) = \xi_{d1}^i(t)$  be the current "output" trajectory. Then  $y_i(at)$  with  $a > 1$  can be used to define a more aggressive trajectory. Also, if  $a$  is close to one, then such a trajectory will be close to  $\eta^i$ .

We illustrate this idea with an example. Let  $f = x_2 \frac{\partial}{\partial x_1} + \sin x_1 \frac{\partial}{\partial x_2}$  and  $g = \cos x_1 \frac{\partial}{\partial x_2} + \frac{\partial}{\partial x_3}$  and consider the system  $(f, g)$ . This system is a simplified three dimensional version of the cart and pendulum system where  $x_1$  and  $x_2$  are the angle and angular rate of the inverted pendulum and  $x_3$  is a variable that might represent the position or velocity of the cart. We emphasize that these are not the dynamics of the cart and pendulum system, but rather a dynamics with similar qualities and the desirable feature of easy 3D visualization.

It is easy to check that this system is linearly controllable when  $-\pi/2 < x_1 < \pi/2$ . The one-form

$\omega = x_2 \sin x_1 dx_1 - \cos x_1 dx_2 + \cos^2 x_1 dx_3$  is a characteristic one-form for  $(f, g)$ .

We are interested in finding trajectories from  $x_0 = (0, 0, 0)$  to  $x_1 = (0, 0, 1)$  using the above algorithm. The results obtained by two iterations of the above algorithm are presented in Figures 1 and 2.

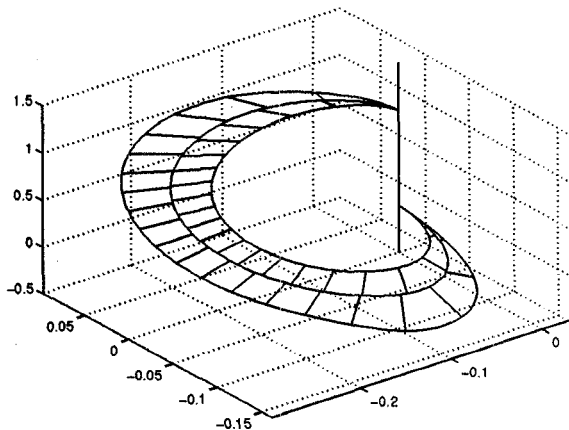

Figure 1: The trajectories  $\eta^0$ ,  $\eta^1$  and  $\eta^2$ .

The initial trajectory  $\eta^0$  between  $x_0$  and  $x_1$  was found using a feedback linearizable approximation valid around the equilibrium manifold  $\mathcal{E} = \{x \in \mathbb{R}^3 : x_1 = x_2 = 0\}$  as suggested in [3]. Of course, the use of such an approximation is limited to a neighborhood of  $\mathcal{E}$ .

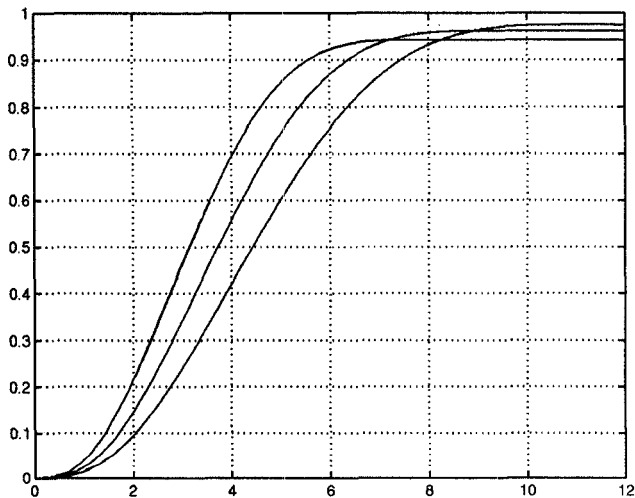

Figure 2: The “output” trajectories  $z_1^0(t)$ ,  $z_1^1(t)$ , and  $z_1^2(t)$ .

For each of the successive trajectories, we constructed local coordinates using the homotopy operators  $H^i$  and a stabilizing controller. The aggressiveness parameter  $a$  was chosen to be 1.2 for both iterations. That is, we asked the system to arrive at  $x_1$  approximately 1.2 times as fast as the previous trajec-

tory. This sequence of aggressiveness is illustrated quite well in Figure 2 where the outputs reach steady state at approximate times of 10, 8.3 and 6.9 seconds. Note that the  $z_1$  coordinate corresponding to the point  $x_1$  is slightly different for each trajectory since different homotopy operators are used to define the coordinate systems.

## Conclusions

We have presented an approach for constructing a feedback linearizable nonlinear system approximation that is valid in the neighborhood of a trajectory. The resulting approximation may be used to develop a feedback controller to stabilize the given and neighboring trajectories. This fact was exploited to develop a trajectory planning algorithm for nonlinear systems.

We also believe that these ideas may be used to construct trajectories between arbitrary points in the linearly controllable set by use of an iterative continuation method.

## References

- [1] Andrzej Banaszuk and John Hauser. Approximate feedback linearization: a homotopy operator approach. *SIAM Journal on Control and Optimization*, 34(5):1533–1554, 1996.
- [2] Andrzej Banaszuk, Andrzej Świąch, and John Hauser. Least squares approximate feedback linearization. *Mathematics of Control, Signals, and Systems*, 9:207–241, 1996.
- [3] John Hauser. Nonlinear control via uniform system approximation. *Systems and Control Letters*, 17:145–154, 1991.
- [4] L. R. Hunt, Renjeng Su, and George Meyer. Global transformations of nonlinear systems. *IEEE Transactions on Automatic Control*, AC-28:24–31, 1983.
- [5] Bronislaw Jakubczyk and Witold Respondek. On linearization of control systems. *Bulletin de L’Academie Polonaise des Sciences, Série des sciences mathématiques*, XXVIII:517–522, 1980.
- [6] Arthur J. Krener. Approximate linearization by state feedback and coordinate change. *Systems and Control Letters*, 5:181–185, 1984.
- [7] Zhigang Xu and John Hauser. Higher order approximate feedback linearization about a manifold for multi-input systems. *IEEE Transactions on Automatic Control*, 40:833–840, 1995.