

# IMC based automatic tuning method for PID controllers in a Smith predictor configuration

Ibrahim Kaya\*

*Department of Electrical and Electronics Engineering, Faculty of Engineering, Inonu University, 44069 Malatya, Turkey*

Received 28 June 2002; accepted 15 January 2003

## Abstract

In this paper, a new approach is presented based on relay autotuning of a plant to find parameters for its control using a Smith predictor. A Smith predictor configuration is represented as its equivalent internal model controller (IMC) which provides the parameters of the proportional-integral (PI) or proportional-integral-derivative (PID) controller to be defined in terms of the desired closed-loop time constant, which can be adjusted by the operator, and the parameters of the process model. This means that only one parameter, namely the desired closed-loop time constant, is left for tuning, assuming that the model parameters have been obtained from a relay autotuning. The ISE criterion was used to find the filter parameter, and simple equations were obtained to tune the Smith predictor. The method is very simple and has given improved results when compared with some previous approaches.

© 2003 Elsevier Ltd. All rights reserved.

*Keywords:* Relay autotuning; PID controller; Smith predictor; IMC control

## 1. Introduction

Proportional-integral-derivative (PID) controllers are still widely used in industrial systems despite the significant developments of recent years in control theory and technology. This is because they perform well for a wide class of processes. Also, they give robust performance for a wide range of operating conditions. Furthermore, they are easy to implement using analogue or digital hardware and familiar to engineers.

However, plants with long time-delays can often not be controlled effectively using a simple PID controller. The main reason for this is that the additional phase lag contributed by the time-delay tends to destabilise the closed-loop system. The stability problem can be solved by decreasing the controller gain. However, in this case the response obtained is very sluggish.

The Smith predictor, shown in Fig. 1, is well known as an effective dead-time compensator for a stable process with long time-delays (Smith, 1959). The performance of the Smith predictor control strategy is affected by the accuracy

with which the model represents the plant. Based on the assumption that the model used matches perfectly the plant dynamics, the closed-loop transfer function is given by

$$T(s) = \frac{G_c(s)G_m(s)e^{-L_m s}}{1 + G_c(s)G_m(s)} \quad (1)$$

According to Eq. (1), the parameters of the primary controller,  $G_c(s)$ , which is typically taken as PI or PID, may be determined using a model of the delay free part of the plant.

Many possible approaches for determining or tuning the parameters of an appropriate controller,  $G_c(s)$ , have been given in the literature and some recent contributions include references (Åström, Hang, & Lim, 1994; Hägglund, 1992; Kaya & Atherton, 1999; Watanabe & Ito, 1981). However, only a few investigations have been carried out on autotuning of the Smith predictor, which recently include (Benouarets & Atherton, 1994; Hang, Wang, & Cao, 1995; Palmor & Blan, 1994). In Benouarets and Atherton (1994), the relay autotuning of Åström and Hägglund (1984) for simple single input single output systems was extended to Smith predictors. In Palmor and Blan (1994) and Hang et al. (1995), a first-order plus dead time (FOPDT) or second-order plus dead time (SOPDT) transfer function model is first found from relay autotuning based on approximate describing function (DF) analysis, then the controller parameters are calculated using

\* Fax: +90-422-340-1046.

E-mail address: [ikaya@inonu.edu.tr](mailto:ikaya@inonu.edu.tr) (I. Kaya).

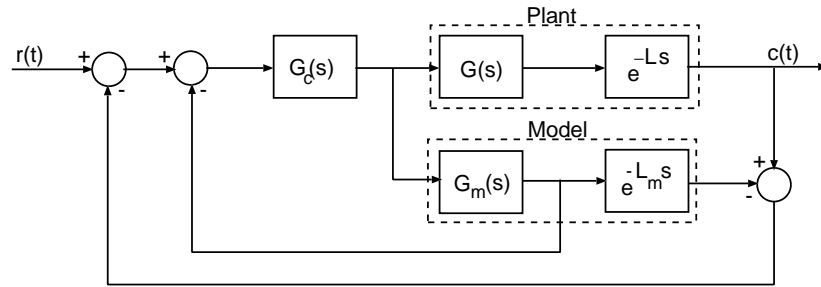

Fig. 1. The Smith predictor control scheme.

parameters of the obtained model. However, all have their own shortcomings. For example, the method proposed by Benouarets and Atherton (1994) is not applicable when the process can be modelled by the FOPDT model, in the case of a perfect matching, as a limit cycle cannot be obtained. Also, the method proposed results in high controller gains, which may cause the saturation problem in practice and makes the method very sensitive to modelling errors. Methods proposed by Hang et al. (1995) and Palmor and Blan (1994) may result in very poor model parameters estimates, especially for processes with small time constants and large time delays, as the approximate DF analysis is used. Also, for the method of Hang et al. (1995), first a relay test has to be performed to use the limit cycle frequency and amplitude for calculating initial PI controller parameters and then putting this PI controller into the closed-loop to find the process steady-state gain so that the all three unknown parameters of the FOPDT or SOPDT model transfer function can be found, which is a time taking process, especially for processes with large time constants. For the method of Palmor and Blan (1994) two relay tests have to be performed to calculate the all three parameters of the FOPDT model, which is again a time taking process.

In this paper, a new approach is presented based on auto-tuning to find the controller parameters for a Smith predictor. A single relay feedback test is performed on the plant and the frequency and amplitude of the resulting limit cycle are measured. Then the A-Locus method, an exact method for giving the parameters of a limit cycle, is used to estimate the parameters of the process model, assumed to be either a FOPDT or SOPDT transfer function. However, the details of the parameter estimation is not given here and interested readers may refer to Kaya (1999) and Kaya and Atherton (2001). Once the model of the process is found, the parameters of the controller, usually a PI or PID, are found to complete the design. Tuning parameters are found by representing the Smith predictor as its equivalent internal model controller (IMC) (Morari & Zafriou, 1989; Rivera, Morari, & Sigurd, 1986), which provides the parameters of the PI or PID controller to be defined in terms of the desired closed-loop time constant, which can be adjusted by the operator, and the parameters of the process model.

The method has the advantage when compared with the methods of Hang et al. (1995) and Palmor and Blan (1994),

of requiring less time for model parameter estimation, since only a single relay feedback test is performed for the proposed method, while for the formers a step or a second relay test have to be performed. Also more accurate parameter estimations can be achieved since an exact limit cycle investigation method is used. Also, the proposed method is the most robust to modelling errors amongst the three as will be shown later by examples.

## 2. Internal model control (IMC)

A control system design is expected to provide a fast and accurate set-point tracking, that is, the output of the system should follow the input signal as close as possible. Also, any external disturbances must be corrected by the control system as efficiently as possible. The first requirement can be achieved by an open loop control system. With an open loop control scheme, the stability of the system is guaranteed provided that both the plant and controller transfer functions are stable. Also, the design of the controller in an open loop control scheme may simply be chosen as  $G_c(s) = G^{-1}(s)$ , where  $G_c(s)$  and  $G(s)$  are respectively the controller and plant transfer functions. The drawback of an open loop control system is the sensitivity to modelling errors and inability to deal with external disturbances entering the system. In this case, a closed-loop system can be used to deal with disturbances and modelling errors. Based on these discussions, Rivera et al. (1986) proposed the control structure given in Fig. 2.

This control structure is referred to as IMC since the plant model,  $\tilde{G}$  appears in the control structure. Here,  $G$  and  $\tilde{G}$

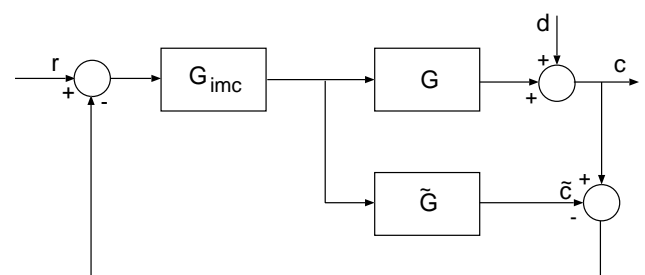

Fig. 2. IMC control strategy.

are the actual process and process model transfer functions respectively. When  $G = \tilde{G}$ , that is perfect modelling, and  $d = 0$ , the system is basically open loop. This provides the open loop advantages. When  $G \neq \tilde{G}$  or  $d \neq 0$  the system is a closed-loop system. Thus, the IMC control strategy has the advantages of both the open loop and closed-loop structures.

From the block diagram of the IMC structure shown in Fig. 2, the closed-loop transfer is given by

$$T_r(s) = \frac{G(s)G_{\text{IMC}}(s)}{1 + [G(s) - \tilde{G}(s)]G_{\text{IMC}}(s)} \quad (2)$$

The disturbance transfer function of the IMC structure is

$$T_d(s) = \frac{1 - \tilde{G}(s)G_{\text{IMC}}(s)}{1 + [G(s) - \tilde{G}(s)]G_{\text{IMC}}(s)} \quad (3)$$

Some important properties of the IMC system (Morari & Zafriou, 1989) are discussed below.

**Property 1** (Dual stability). *Assume that the model and plant dynamics match perfectly,  $G(s) = \tilde{G}(s)$ . Then the stability of both the plant and controller is sufficient for the stability of the overall closed-loop system.*

**Proof.** From Fig. 2, the output of the system, assuming  $G(s) = \tilde{G}(s)$ , is given by

$$C(s) = G(s)G_{\text{IMC}}(s)[R(s) - D(s)] + D(s)$$

Thus for stable  $G(s)$  and  $G_{\text{IMC}}(s)$ , the closed loop system is stable.  $\square$

**Property 2** (Perfect controller). *Assume that the IMC controller is designed to be given by the model inverse,  $G_{\text{IMC}}(s) = \tilde{G}(s)^{-1}$  and that the closed-loop IMC system is stable. Then, the perfect reference tracking,  $C(s) = R(s)$ , can be achieved for all time  $t > 0$  despite any disturbance  $D(s)$ .*

**Proof.** For  $G_{\text{IMC}}(s) = \tilde{G}(s)^{-1}$ , the closed-loop and disturbance transfer functions, from Eqs. (2) and (3), are respectively given by  $T_r(s) = 1$  and  $T_d(s) = 0$ . This means perfect reference tracking and complete disturbance rejection can be achieved.  $\square$

However, the perfect controller property is of theoretical interest only. It is known that with  $G_{\text{IMC}}(s) = \tilde{G}(s)^{-1}$  modelling errors may lead to an unstable system. Moreover, the perfect controller given by Property 2 cannot be realised for several reasons (Morari & Zafriou, 1989; Rivera et al., 1986).

Thus, the first step in the IMC controller design is to factor the process model

$$\tilde{G}(s) = \tilde{G}_+(s)\tilde{G}_-(s) \quad (4)$$

where  $\tilde{G}_+$  contains all the time delays and right-half plane zeros. The second step is to define the IMC controller as

$$G_{\text{IMC}}(s) = \tilde{G}_-^{-1}(s)F(s) \quad (5)$$

where  $F(s)$  is a low pass filter with a steady state gain of one. The filter is introduced for physical realisability of the IMC controller,  $G_{\text{IMC}}(s)$ . The simplest filter has the following form (Morari & Zafriou, 1989; Rivera et al., 1986)

$$F(s) = \frac{1}{(\lambda s + 1)^n} \quad (6)$$

Substituting Eq. (5) into Eqs. (2) and (3) gives

$$T_r(s) = \frac{G(s)F(s)}{\tilde{G}_-(s) + [G(s) - \tilde{G}(s)]F(s)} \quad (7)$$

and

$$T_d(s) = \frac{\tilde{G}_-(s)[1 - F(s)]}{\tilde{G}_-(s) + [G(s) - \tilde{G}(s)]F(s)} \quad (8)$$

For perfect modelling,  $G(s) = \tilde{G}(s)$ , and non-minimum phase systems,  $\tilde{G}_-(s) = \tilde{G}(s)$ , Eqs. (7) and (8) can be further simplified to give

$$T_r(s) = F(s) \quad (9)$$

and

$$T_d(s) = 1 - F(s) \quad (10)$$

Eqs. (9) and (10) clearly show that the performance of a closed-loop system designed based on the IMC design method is determined solely by the filter dynamics. For a filter with the form given by Eq. (6) and for  $t \rightarrow \infty$ , Eqs. (9) and (10) give  $T_r(s) \rightarrow 1$  and  $T_d(s) \rightarrow 0$ .

It is shown (Rivera et al., 1986) that the IMC controller design method leads to PID controllers for many of the plant transfer function models used in industrial practice. In the next section, the IMC design method is used to design PID controllers in a Smith predictor configuration.

### 3. IMC representation of a smith predictor

The closed-loop transfer function of a Smith predictor, assuming a perfect matching, is given (see Fig. 1 and Eq. (1)) by

$$T_{\text{Smith}}(s) = \frac{G_c(s)G_m(s)e^{-L_m s}}{1 + G_c(s)G_m(s)} \quad (11)$$

The closed-loop transfer function of the IMC design, assuming a perfect matching and  $d = 0$ , is given by

$$T_{\text{IMC}}(s) = G_{\text{IMC}}(s)G(s) \quad (12)$$

which can be rearranged as

$$T_{\text{IMC}}(s) = G_{\text{IMC}}(s)G_m(s)e^{-Ls} \quad (13)$$

where  $G_m(s)$  is the delay free part of the model transfer function. To have the same output for the both configurations, it is straightforward to illustrate, by comparing Eqs. (11) and

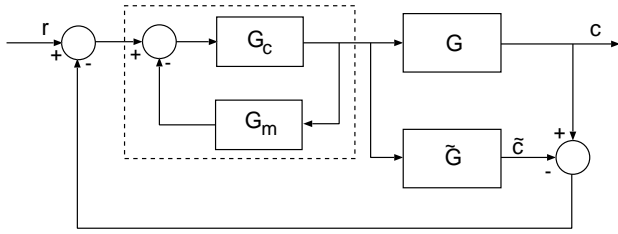

Fig. 3. IMC representation of a Smith predictor.

(13), that the IMC controller,  $G_{\text{IMC}}(s)$ , is related to the classic controller,  $G_c(s)$ , through the transformation

$$G_{\text{IMC}}(s) = \frac{G_c(s)}{1 + G_c(s)G_m(s)} \quad (14)$$

or

$$G_c(s) = \frac{G_{\text{IMC}}(s)}{1 - G_{\text{IMC}}(s)G_m(s)} \quad (15)$$

Therefore, from Eq. (14), a Smith predictor structure can be put into the IMC structure as shown in Fig. 3.

To find the tuning parameters for the controller  $G_c(s)$  in Fig. 3, first a FOPDT transfer function is considered. In order to obtain the IMC controller, the process model,  $\tilde{G} = K_m e^{-L_m s} / (T_m s + 1)$ , must be factored as in Eq. (4). If a first-order Taylor series expansion is used for the time-delay approximation, then the following equations are obtained

$$\tilde{G}_+(s) = (1 - L_m s) \quad (16)$$

$$\tilde{G}_-(s) = \frac{K_m}{T_m s + 1} \quad (17)$$

The IMC controller can be obtained from Eq. (5), assuming a filter with  $n = 1$ , as

$$G_{\text{IMC}}(s) = \frac{T_m s + 1}{K_m (\lambda s + 1)} \quad (18)$$

Eq. (18) shows that, once the parameters of the model,  $K_m$  and  $T_m$ , are known, then only the filter parameter,  $\lambda$ , remains to be selected. The classic controller,  $G_c$ , can then be obtained using Eq. (15) to give

$$G_c = \frac{T_m s + 1}{K_m \lambda s} \quad (19)$$

Eq. (19) can be rearranged as an ideal PI controller, which has the following controller parameters

$$K_p = \frac{T_m}{K_m \lambda} \quad (20)$$

and

$$T_i = T_m \quad (21)$$

The only unknown in the last two equations is the filter time constant,  $\lambda$ , since it is assumed that the plant transfer function model is obtained using the relay feedback method given in Kaya (1999) and Kaya and Atherton (2001). Thus, if a proper value of  $\lambda$  is achieved, then the design procedure

will be completed. Here, the Integral Squared Error, ISE, criterion, which is given by

$$J_{\text{ISE}} = \int_0^{\infty} [r - c(t)]^2 dt \quad (22)$$

is used to find an optimal solution for the filter parameter,  $\lambda$ . The Laplace form of the output signal,  $C(s)$ , in the Smith predictor configuration can be obtained from Fig. 1,

$$\frac{C(s)}{R(s)} = \frac{G_c G_m}{1 + G_c G_m} e^{-L_m s} \quad (23)$$

assuming a perfect matching between the process and model. Substituting the proper values for  $G_c(s)$  given by Eq. (19) and  $G_m(s) = K_m / (T_m s + 1)$  into Eq. (23) and assuming a unit step change into the system gives

$$C(s) = \frac{1}{s(\lambda s + 1)} e^{-L_m s} \quad (24)$$

The time domain solution is obtained by assuming a first-order Taylor series expansion:

$$c(t) = 1 - \left(1 + \frac{L_m}{\lambda}\right) e^{-t/\lambda} \quad (25)$$

Putting Eqs. (22) into (25) results in

$$J_{\text{ISE}} = \frac{(\lambda + L_m)^2}{2\lambda} \quad (26)$$

Taking the derivative of Eq. (26) with respect to  $\lambda$ , produces  $\lambda = L_m$ . Finally the PI controller parameters are

$$K_p = \frac{T_m}{K_m L_m} \quad (27)$$

$$T_i = T_m \quad (28)$$

Processes with SOPDT transfer functions are also very common. This is why a similar result to that for the FOPDT transfer function is also derived for the SOPDT transfer function. Following the same procedure as for the FOPDT transfer function and assuming  $\tilde{G}(s) = K_m e^{-L_m s} / (T_{1m} s + 1)(T_{2m} s + 1)$ , it can easily be shown that the classical controller can now be implemented as a PID controller with the following parameters

$$K_p = \frac{T_{1m} + T_{2m}}{K_m L_m} \quad (29)$$

$$T_i = T_{1m} + T_{2m} \quad (30)$$

$$T_d = \frac{T_{1m} T_{2m}}{T_{1m} + T_{2m}} \quad (31)$$

With the calculated filter time constant, that is  $\lambda = L_m$ , the closed-loop response of the system may be slow for processes with large time delays and small time constant and steady state gain since this results in a small controller gain from Eq. (27) for the PI and Eq. (29) for the PID controller. This, however, gives a larger margin for the closed-loop system to be unstable as shown in the next section.

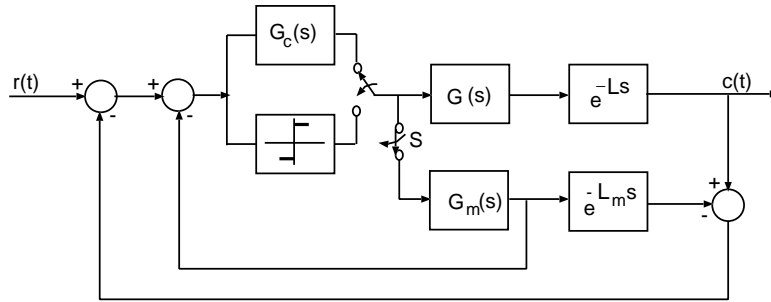

Fig. 4. Block diagram for autotuning of the Smith predictor.

In order to obtain a faster closed-loop response in the case of small ratios of  $T_m/K_m L_m$  for the PI and  $(T_{1m} + T_{2m})/K_m L_m$  for the PID controller gains, a constant  $0.2 < \alpha < 1$  can be introduced into these expressions. In this case, the controller gain for the PI controller is given by

$$K_p = \frac{T_m}{\alpha K_m L_m} \quad (32)$$

and for the PID controller is

$$K_p = \frac{T_{1m} + T_{2m}}{\alpha K_m L_m} \quad (33)$$

### 3.1. Autotuning procedure

The block diagram for autotuning of the Smith predictor configuration is shown in Fig. 4. The autotuning procedure to find controller parameters can be carried out as follows:

- When the controller needs to be tuned, switch from the controller mode to relay mode. At the same time, open the switch “S” so that the original relay feedback configuration is obtained.
- Measure the limit cycle parameters and estimate parameters for the FOPDT or SOPDT model plant transfer function using the relay feedback method proposed by Kaya (1999) and Kaya and Atherton (2001).
- Find tuning parameters using either Eqs. (27) and (28), if the FOPDT model is used, or Eqs. (29)–(31), if the SOPDT model is used.
- Switch from relay mode to controller mode with calculated tuning parameters for the control of the process.

## 4. Robustness analysis of the performance

The robustness analysis of the proposed controller design is done using the block diagram shown in Fig. 1. The characteristic equation of the system given in Fig. 1 is

$$1 + G_c(s)G_m(s) + G_c(s)[P(s) - P_m(s)] = 0 \quad (34)$$

where  $P(s) = G(s)e^{-Ls}$  is the actual plant transfer function and  $P_m(s) = G_m(s)e^{-Lms}$  is the model of the plant. If the uncertainties are given by  $P(s) = P_m(s) + \delta P(s)$ , where

the  $\delta P(s)$  is the uncertainty in  $P(s)$ , then Eq. (34) can be rearranged as

$$1 + G_c(s)G_m(s) + G_c(s)\delta P(s) = 0 \quad (35)$$

which then gives

$$|\delta P(s)| = \frac{|1 + G_c(s)G_m(s)|}{|G_c(s)|} \quad (36)$$

the norm bound uncertainty region (Morari & Zafriou, 1989) in order to maintain the closed-loop stability. Note that this norm boundary is the same as the one obtained if the system has no time delay in the plant transfer function.

Substituting for  $G_m(s) = K_m/(T_ms + 1)$  and  $G_c(s)$ , from Eq. (19), for the case when the plant is modelled by the FOPDT transfer function gives

$$|\delta P(s)|_{\text{FOPDT}} = \frac{K_m \sqrt{\lambda^2 \omega^2 + 1}}{\sqrt{T_m^2 \omega^2 + 1}} \quad (37)$$

For low frequencies the norm bound uncertainty region for  $|\delta P(s)|_{\text{FOPDT}}$  is given by the steady state gain of the model  $K_m$ . The magnitude of the modelling errors,  $|P(j\omega) - P_m(j\omega)|$ , at low frequencies is given by  $(K - K_m)$ . This illustrates that at low frequencies, the closed-loop stability is only affected by the uncertainties in the steady state gains of the plant and model. Also, it is seen that very high modelling errors, that is 100%, in the plant and model steady state gains are allowed for maintaining the closed-loop stability. For high frequencies the norm bound is given by  $K_m \lambda / T_m$ . Thus, the larger the value of the filter time constant the larger norm bound uncertainty region, that is, the permission for larger modelling errors.

Similarly the norm bound uncertainty region for the case when the plant is modelled by the SOPDT is obtained as

$$|\delta P(s)|_{\text{SOPDT}} = \frac{K_m \sqrt{\lambda^2 \omega^2 + 1}}{\sqrt{[1 - (T_{1m} T_{2m} \omega)^2]^2 + (T_{1m} + T_{2m})^2 \omega^2}} \quad (38)$$

For low frequencies the norm bound uncertainty region for  $|\delta P(s)|_{\text{SOPDT}}$  is again given by the steady state gain of the model  $K_m$ . Since the modelling errors are again given by  $(K - K_m)$ , a very high value for modelling errors, namely 100%, is allowed at low frequencies. For  $\omega \rightarrow \infty$ ,

$|\delta P(s)|_{\text{SOPDT}} \rightarrow 0$ . Thus, this implies that the choice of  $\lambda$  does not affect the stability of the closed-loop system at high frequencies. As it is shown by an example, the mid-frequencies are more effective on the stability of the system, therefore it can still be expected that the larger values of  $\lambda$  gives larger margins to maintain the closed-loop system stability.

To see the effect of on the system performance, Eqs. (37) and (38) can be rearranged by using Eqs. (32) and (33) rather than Eqs. (27) and (29), respectively. In this case, the numerator of Eqs. (37) and (38) will be given by  $K_m \sqrt{\lambda^2 \omega^2 \alpha^2 + 1}$ .

## 5. Illustrative examples

Several examples are given to illustrate the use of the proposed design method. In the first example, a SOPDT plant transfer function is considered to show the effect of the choice of  $\alpha$  on the system performance and robustness. The second and third examples are given to compare the performance of the proposed design method with some existing design approaches.

**Example 1.** In this example, a process with SOPDT transfer function

$$G(s) = \frac{e^{-10s}}{(17s + 1)(6s + 1)}$$

where  $T_{1m} + T_{2m}$  is larger than  $K_m L_m$ , therefore it is expected that for  $\alpha = 1$  a satisfactory closed-loop response can be obtained, is considered. Since the transfer function fits to the SOPDT model perfectly, the parameter estimation

method given in Kaya and Atherton (1999, 2001) is used to obtain the model transfer function accurately. Closed-loop step responses for different  $\alpha$  values are shown in Fig. 5. As expected the closed-loop response of the system is satisfactory for  $\alpha = 1$ , since  $(T_{1m} + T_{2m}) > K_m L_m$ . For +10 and -10% change in the time delay, step responses are given in Figs. 6 and 7, respectively. Smaller values of  $\alpha$  decrease the robustness of the system as expected. The modelling errors and norm bound uncertainty region are shown in Fig. 8 which illustrates that smaller  $\alpha$  values decrease the norm bound uncertainty region and thus the relative stability of the system.

**Example 2.** A SOPDT plant transfer function

$$G(s) = \frac{e^{-10s}}{(s + 1)^2}$$

is considered. The identification method given in Kaya and Atherton (1999, 2001) was used to find parameters of the FOPDT model as  $G(s) = e^{-10.87s}/(1.27s + 1)$  and the SOPDT model as  $e^{-10s}/(s + 1)^2$ . Using the tuning formulae given in Section 3 with  $\alpha = 0.5$  results in  $K_c = 0.234$  and  $T_i = 1.27$  for a PI controller and  $K_c = 0.400$ ,  $T_i = 2.000$  and  $T_d = 0.500$  for a PID controller. The controller parameters for the method proposed by Hang et al. (1995) are  $K_c = 0.510$  and  $T_i = 1.780$ , for the method proposed by Palmor and Blan (1994) are  $K_c = 0.956$  and  $T_i = 2.680$  and for the method proposed by Benouarets and Atherton (1994) are  $K_c = 4.703$ ,  $T_i = 1.036$  and  $T_d = 0.251$ . User specified value of damping ratio  $\zeta$  was chosen equal to 0.7 for the method of Hang et al. (1995). The controller proposed by Benouarets and Atherton (1994)

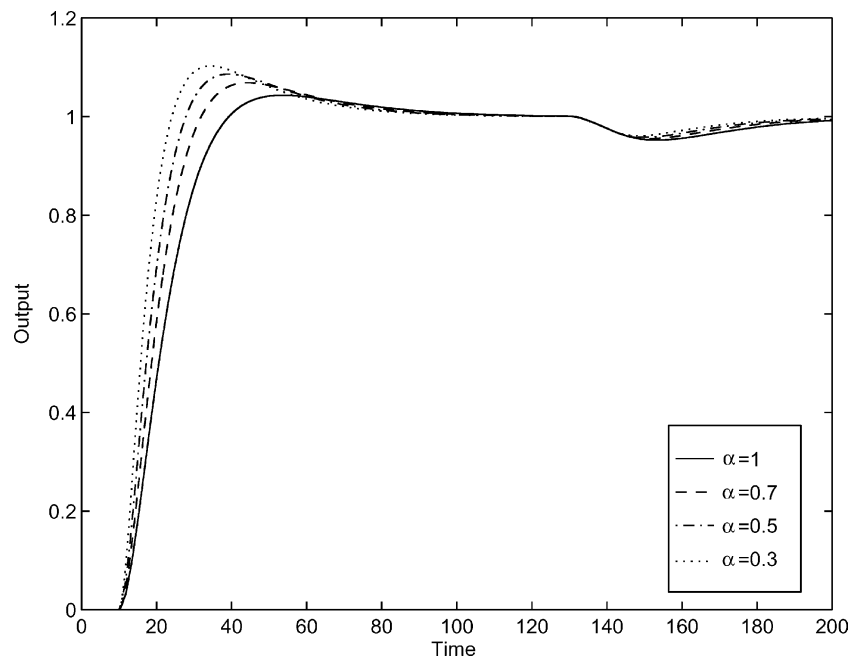

Fig. 5. Responses for Example 1.

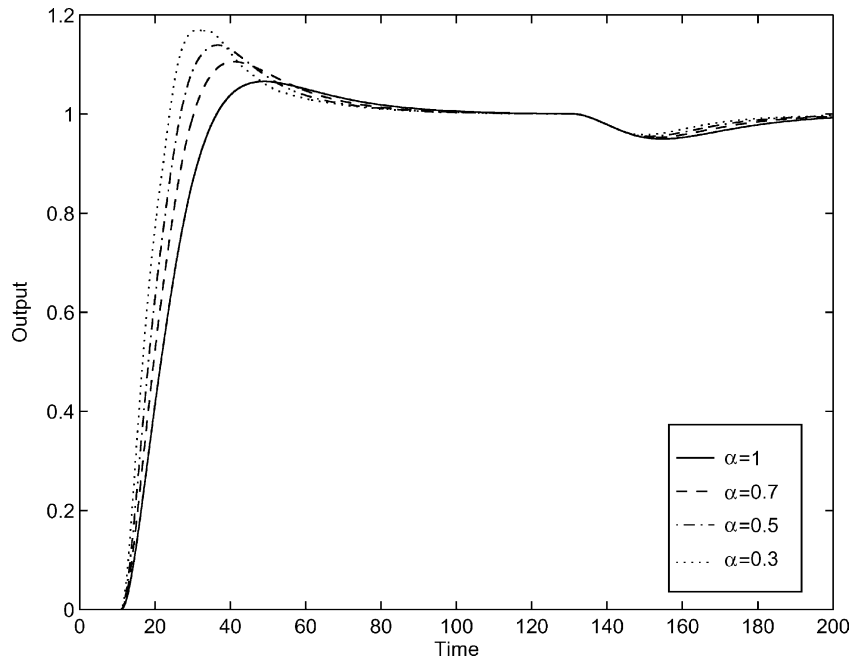

Fig. 6. Responses of Example 1 for +10% change in the time delay.

was designed for a gain and phase margins of 0.6 and  $60^\circ$ , respectively. Responses to a unit step input change and disturbance with magnitude of  $-0.2$  at  $t = 70s$  are given in Fig. 9. Certainly, the proposed method gives the best performance. Since, the Smith predictor controller is sensitive to modelling errors, especially to a mismatch in the dead time, results are also given for a +30% change in the plant time delay in Fig. 10. Again the proposed method results in best performance. Note that the design

method of Palmor and Blan (1994) results in an unstable response. Also, the result for design method of Benouarets and Atherton (1994) is not shown as it causes an unstable response immediately.

**Example 3.** A high order plant transfer function

$$G(s) = \frac{e^{-20s}}{(3s + 1)(2s + 1)(s + 1)(0.5s + 1)}$$

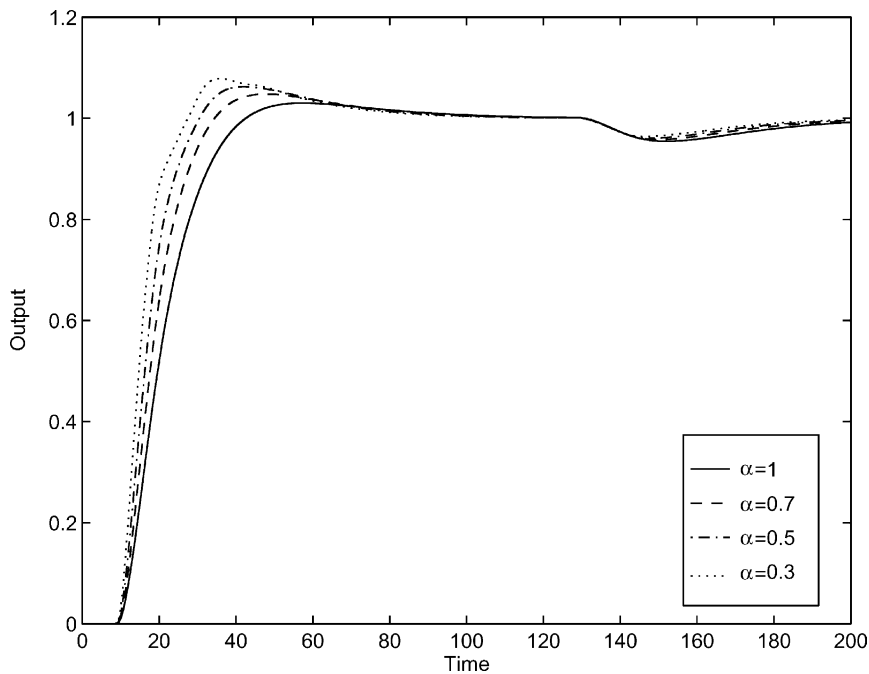

Fig. 7. Responses of Example 1 for -10% change in the time delay.

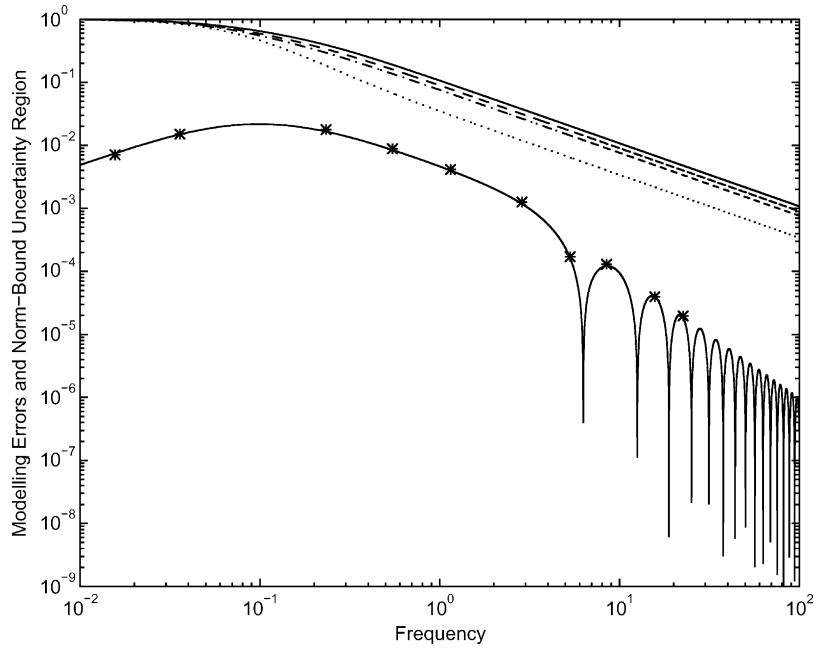

Fig. 8. Modelling errors (✱) for  $L = 11$  and norm-bound uncertainty ((—)  $\alpha = 1$ , (---)  $\alpha = 0.7$ , (-.-)  $\alpha = 0.5$ , (···)  $\alpha = 0.3$ ) of Example 1.

is considered. Again, the identification method proposed in Kaya and Atherton (1999, 2001) was used to find parameters of the FOPDT model as  $G(s) = e^{-23.28s}/(3.67s + 1)$  and the SOPDT model as  $e^{-21.01}/(2.77s + 1)^2$ . The tuning formulae given in Section 3 was used to obtain  $K_c = 0.315$  and  $T_i = 3.670$  for a PI controller and  $K_c = 0.527$ ,  $T_i = 5.540$  and  $T_d = 1.385$  for a PID controller for  $\alpha = 0.5$ .

The controller parameters for the design method of Hang et al. (1995) are  $K_c = 0.510$  and  $T_i = 4.301$ , for the design method of Palmor and Blan (1994) are  $K_c = 0.960$  and  $T_i = 6.489$  and for the design method of Benouarets and Atherton (1994) are  $K_c = 1.873$ ,  $T_i = 5.350$  and  $T_d = 1.340$ . User specified value of damping ratio  $\zeta$  was again chosen equal to 0.7 for the method of Hang et al. (1995). The controller

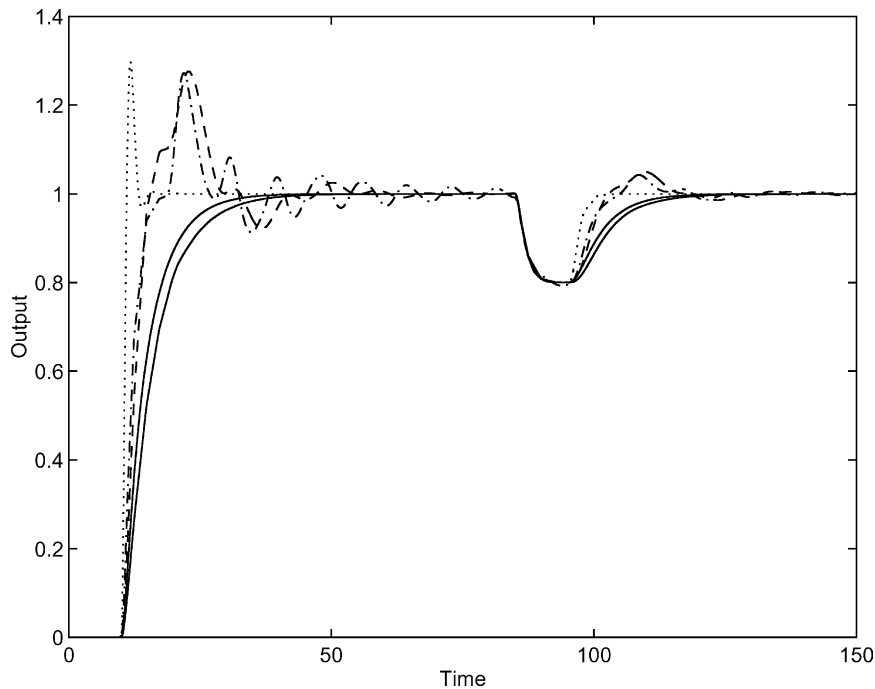

Fig. 9. Responses of Example 2: (—) proposed method (the faster is for the SOPDT model and the slower is for the FOPDT model), (---) Hang et al. (1995), (-.-) Palmor and Blan (1994), (···) Benouarets and Atherton (1994).



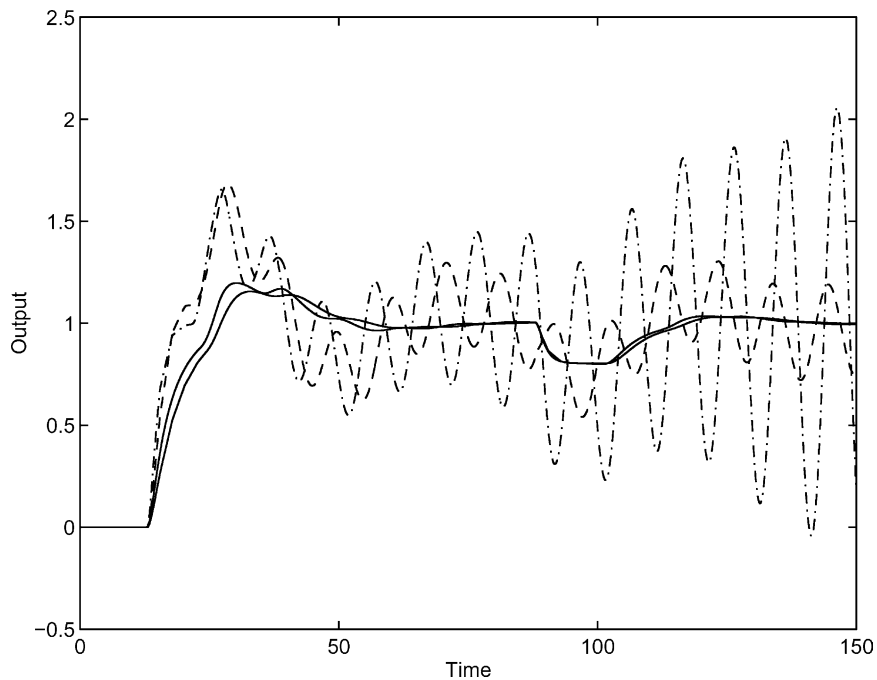

Fig. 10. Responses of Example 2 for +30% change in the plant time delay: (—) proposed method (the faster is for the SOPDT model and the slower is for the FOPDT model), (---) Hang et al. (1995), (-·-) Palmor and Blan (1994).

proposed by Benouarets and Atherton (1994) was designed for the gain and phase margins of 0.6 and  $45^\circ$ . Fig. 11 illustrates responses to a unit step input change and disturbance with magnitude of  $-0.2$  at  $t = 150$ s. The proposed design method again gives better performance than the other de-

sign methods. Fig. 12 shows results when +30% change is assumed in the plant time delay. The proposed method results in a satisfactory response while the design method of Hang et al. (1995) and Palmor and Blan (1994) results in a very poor response. The result for the design method of

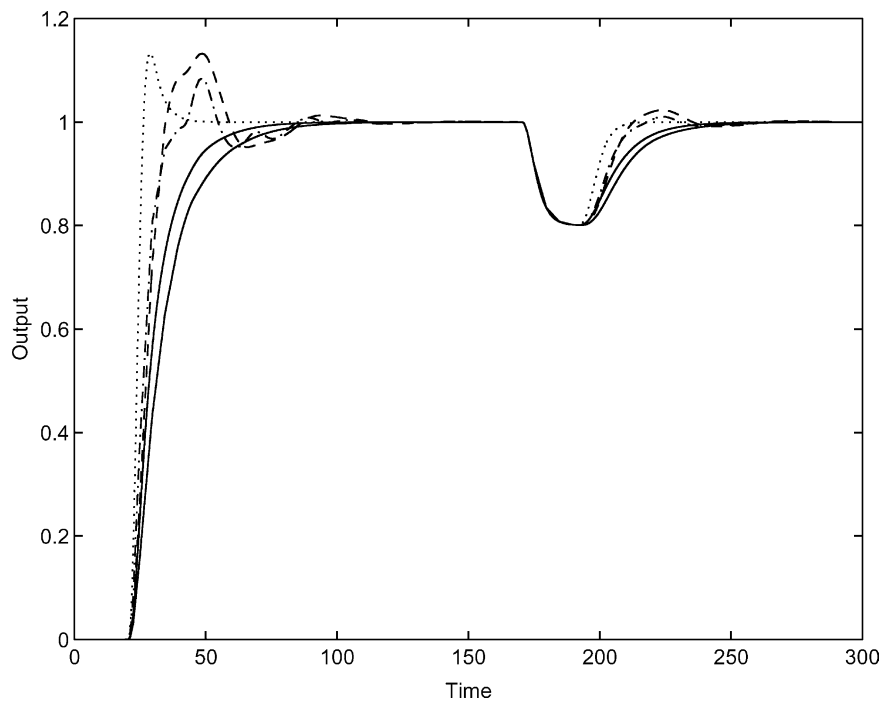

Fig. 11. Responses of Example 3: (—) proposed method (the faster is for the SOPDT model and the slower is for the FOPDT model), (---) Hang et al. (1995), (-·-) Palmor and Blan (1994), (···) Benouarets and Atherton (1994).

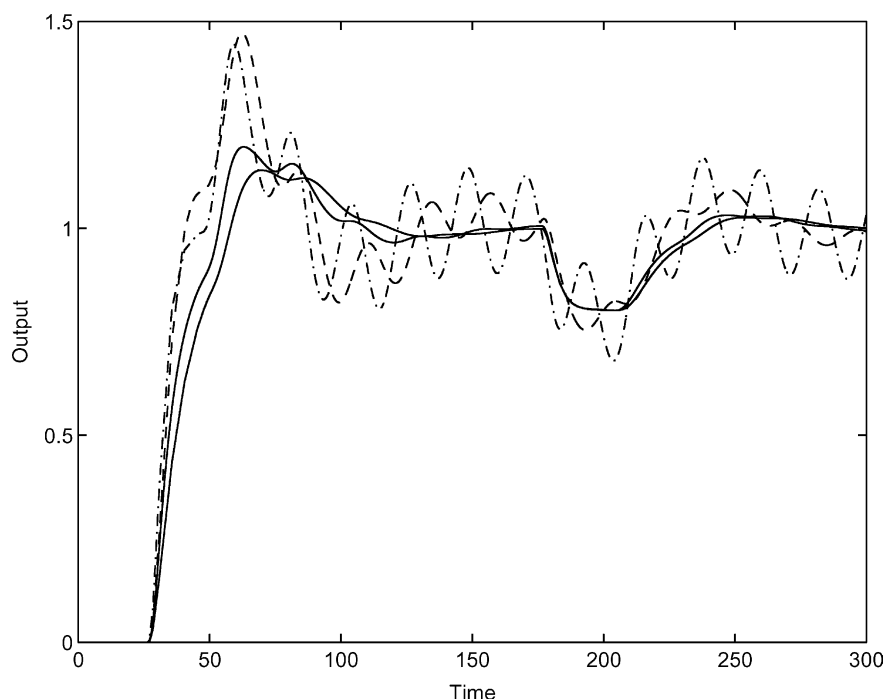

Fig. 12. Responses of Example 3 for +30% change in the plant time delay: (—) proposed method (the faster is for the SOPDT model and the slower is for the FOPDT model), (---) Hang et al. (1995), (· · ·) Palmor and Blan (1994).

Benouarets and Atherton (1994) is again not shown as it results in an unstable response immediately.

## 6. Conclusions

The paper presented an autotuning method for Smith predictor controllers based on exact limit cycle analysis for FOPDT and SOPDT plants. The Smith predictor was represented as its equivalent IMC controller and this enabled to define the PI or PID controller parameters to be defined in terms of the model parameters and the closed-loop time constant,  $\lambda$ . Since it is assumed that the model of the plant can be found using relay autotuning method, this meant that only one parameter, namely the closed-loop time constant  $\lambda$ , was left for tuning. The ISE criterion was used to find the value of  $\lambda$  and simple equations were obtained to tune the Smith predictor. The method is very simple and has given improved results when compared with some previous approaches. Also, some discussions on robustness of the proposed design method have been given.

## References

- Åström, K. J., & Hägglund, T. (1984). Automatic tuning of simple regulators with specifications on phase and amplitude margins. *Automatica*, 20, 645–651.
- Åström, K. J., Hang, C. C., & Lim, B. C. (1994). A new Smith predictor for controlling a process with an integrator and long dead-time. *IEEE Transaction on Automatic Control*, 39(2), 343–345.
- Benouarets, M., & Atherton, D. P. (1994). Autotuning design methods for a Smith predictor control scheme. In *UKACC International Conference on Control'94* (pp. 795–800).
- Hägglund, T. (1992). A predictive PI controller for processes with long dead-time delay. *IEEE Control System Magazine*, 12(1), 57–60.
- Hang, C. C., Wang, Q. G., & Cao, L. S. (1995). Self-tuning Smith predictors for processes with long dead time. *International Journal of Adaptive Control and Signal Processing*, 9, 255–270.
- Kaya, I. (1999). *Relay feedback identification and model based controller design*. D.Phil. Thesis, University of Sussex, UK.
- Kaya, I., & Atherton, D. P. (1999). A new PI-PD Smith predictor for control of processes with long dead time. In *Proceedings of the 14th IFAC World Congress IFAC'99* (pp. 283–288).
- Kaya, I., & Atherton, D. P. (2001). Parameter estimation from relay autotuning with asymmetric limit cycle data. *Journal of Process Control*, 11(4), 429–439.
- Morari, M., & Zafriou, E. (1989). *Robust process control*. Englewood Cliffs: Prentice-Hall.
- Palmor, Z. J., & Blan, M. (1994). An auto-tuner for Smith dead time compensator. *International Journal of Control*, 60(1), 117–135.
- Rivera, D. E., Morari, M., & Sigurd, S. (1986). Internal model control. PID controller design. *Industrial Chemistry in Process Design and Development*, 25(1), 252–265.
- Smith, O. J. (1959). A controller to overcome dead time. *ISA Journal*, 6(2), 28–33.
- Watanabe, K., & Ito, M. (1981). A process-model control for linear systems with delay. *IEEE Transaction on Automatic Control*, AC-26(6), 1261–1266.